

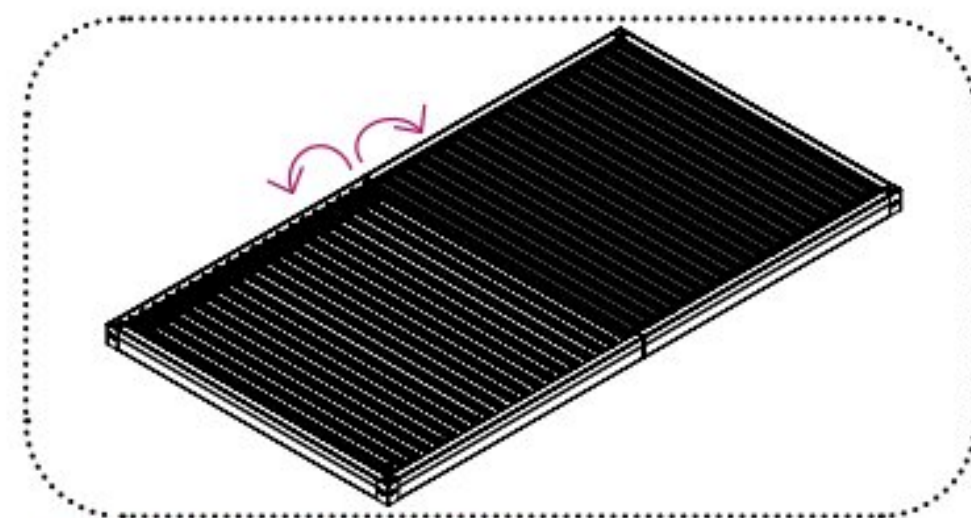

### Plus Tecnici | Technical Plus

+ = optional

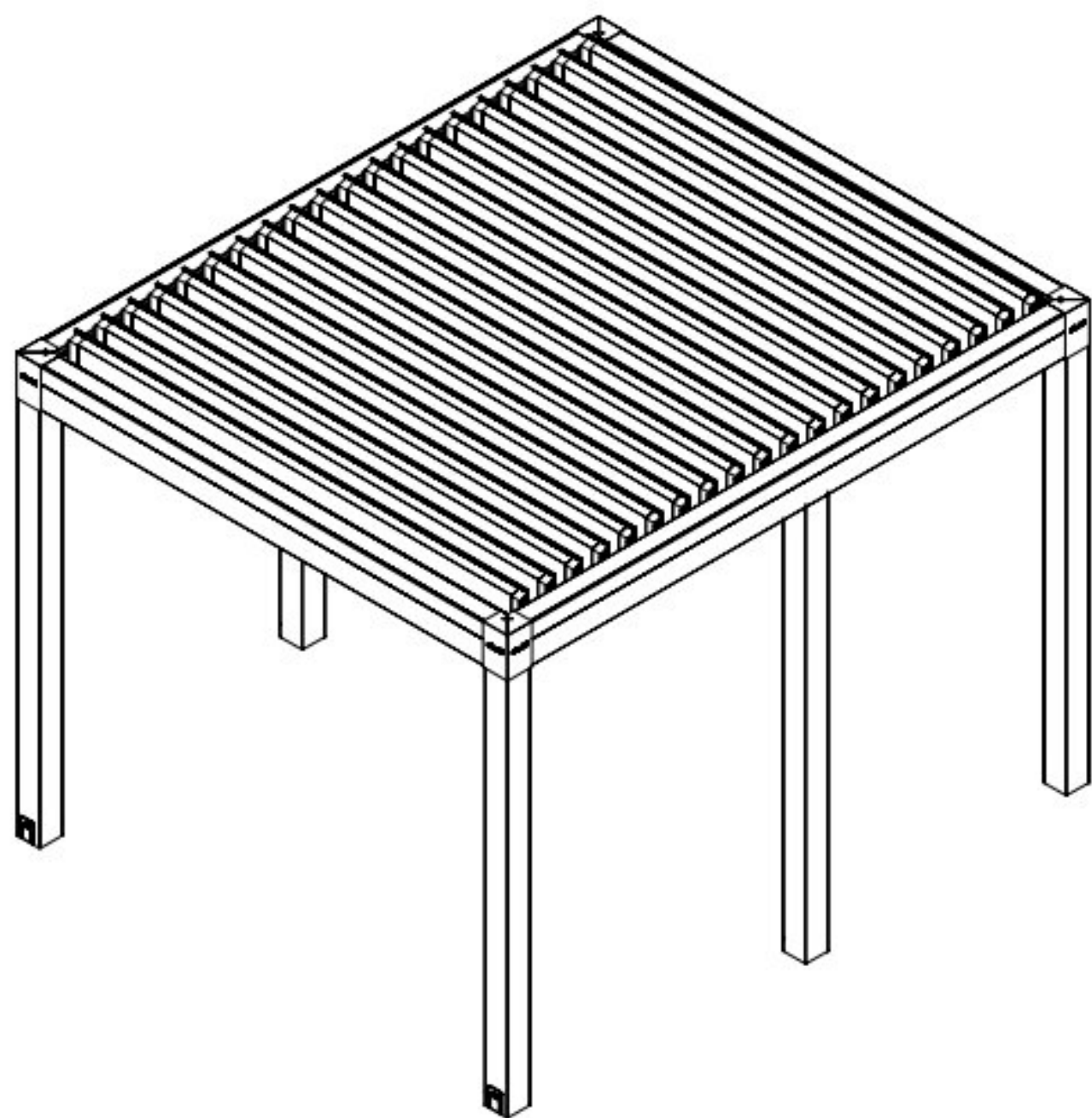

**BREVETTO PATENTED**  
**Dual Orientation System (DOS)**  
Copertura in piano con lame orientabili anche in due settori indipendenti.  
*Flat roof with tilting blades in two independent sectors.*

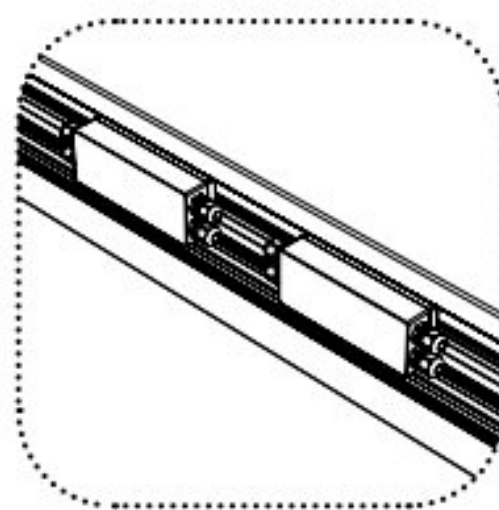

**Vano tecnico ispezionabile**  
Vano tecnico per motori, trasformatori e ricevitori totalmente ispezionabile e facilmente accessibile.  
**Inspectionable technical compartment**  
*Technical compartment for motors, drivers and receivers fully inspectionable and easy to reach.*

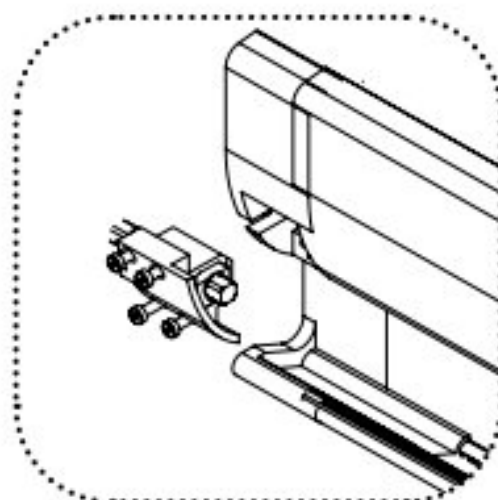

**BREVETTO PATENTED**  
**Hooking & Traction System (HTS)**  
Dispositivo di aggancio rapido delle lame con sistema di trazione per la compensazione dalla flessione da carico.  
*Fast blade hooking device with pulling system for load bending compensation.*

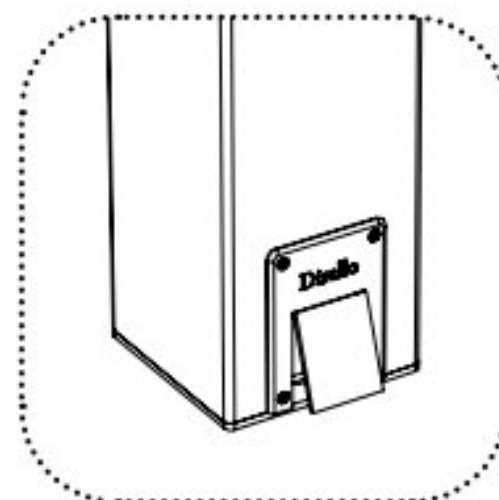

**Sportello deflusso**  
Nuovo sportello di deflusso per lo scarico delle acque piovane.  
**Outflow flap**  
*New rainwater drainage flap.*

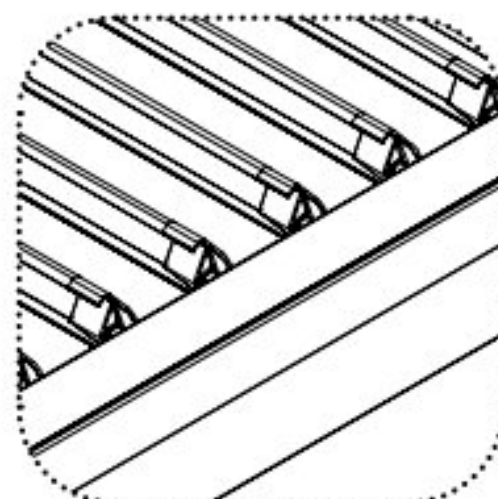

**BREVETTO PATENTED**  
**Lama di copertura**  
Innovativo design che previene le infiltrazioni delle acque piovane.  
**Top blade**  
*Innovative design to protect against rainwater infiltration.*

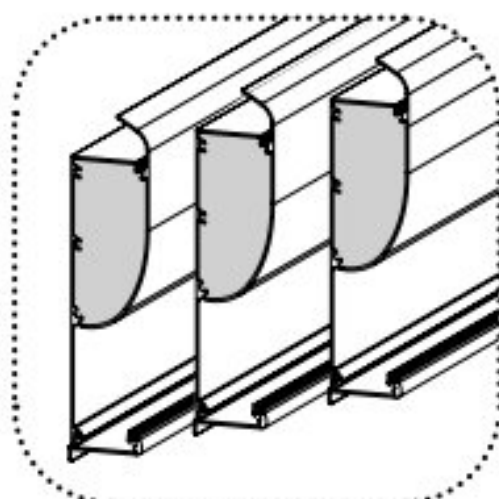

**Lama Soundproof**  
Coibentazione interna delle lame in polistirene espanso per aumentare l'insonorizzazione acustica della copertura.  
**Blades with internal insulation core of expanded polystyrene to improve the acoustic soundproofing of the roof.**

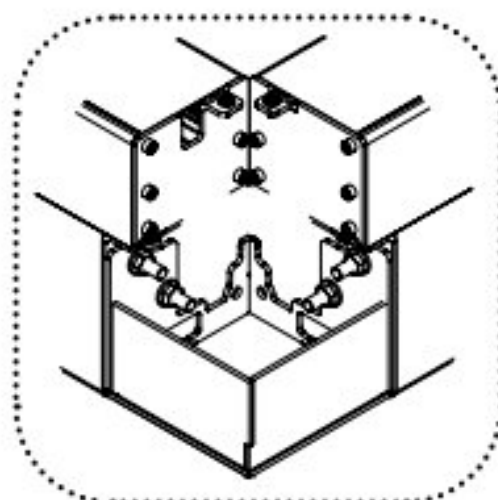

**BREVETTO PATENTED**  
**Angolo Grande**  
Staffa angolare in acciaio inox per rapido collegamento delle gronde.  
**Corner**  
*Stainless steel corner bracket for quick connection.*

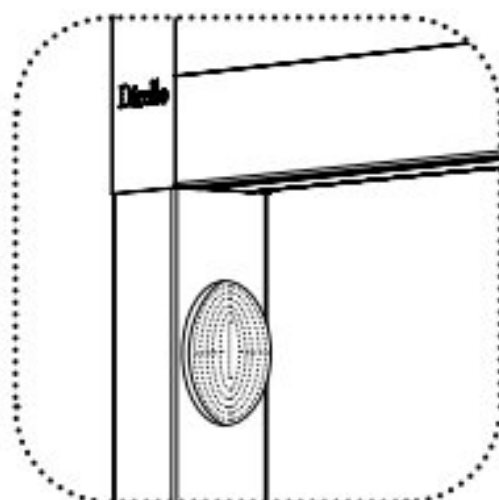

**DIRELLO Concert**  
Sistema audio integrato con tecnologia Bluetooth.  
**Integrated sound system with Bluetooth wireless technology.**

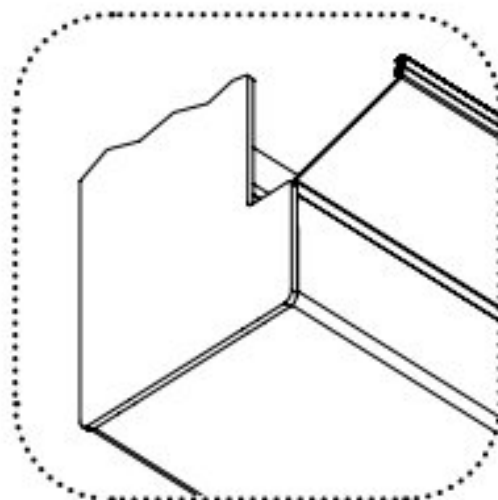

**BREVETTO PATENTED**  
**Ribalta sincronizzata**  
Grondaia perimetrale dotata di ribalta inclinata.  
**Synchronized flap**  
*Perimeter gutter equipped with synchronized flap.*

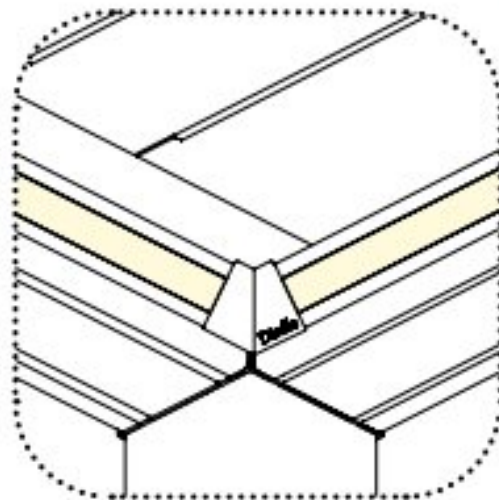

**Outdoor LED System**  
Impianto d'illuminazione a LED integrato nel perimetro della pergola, rifinito con diffusore in policarbonato nelle varianti luce bianca (calda/fredda) e RGB, gestita tramite radiocomando con dimmer.  
**Integrated LED system around the perimeter of the pergola, finished with polycarbonate diffuser in light white (warm/cold) variants and RGB, operated by remote control with dimmer.**

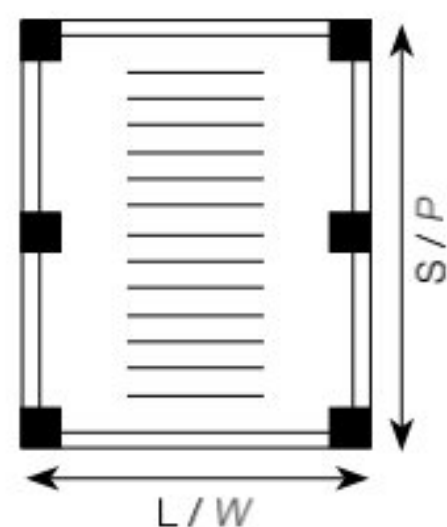

**MODULO SINGOLO**  
Dimensioni massime: L 500 x S 1010

*SINGLE MODULE*  
Max dimensions: W 500 x P 1010

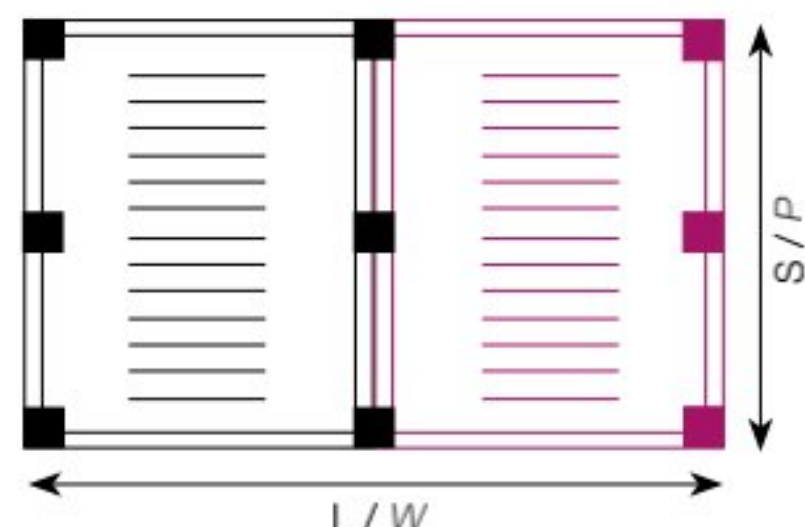

**MODULO DOPPIO  
ACCOPIATO IN LARGHEZZA**  
Dimensioni massime: L 1000 x S 1010

*DOUBLE MODULE  
COUPLED ON WIDTH SIDE*  
Max dimensions: W 1000 x P 1010

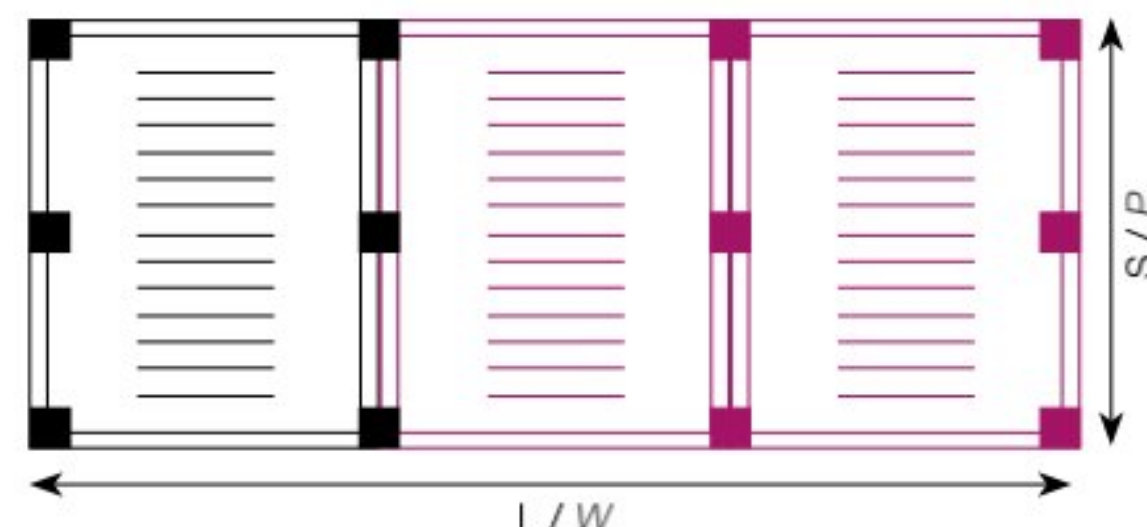

**MODULO TRIPLO  
ACCOPIATO IN LARGHEZZA**  
Dimensioni massime: L 1500 x S 1010

*TRIPLE MODULE  
COUPLED ON WIDTH SIDE*  
Max dimensions: W 1500 x P 1010

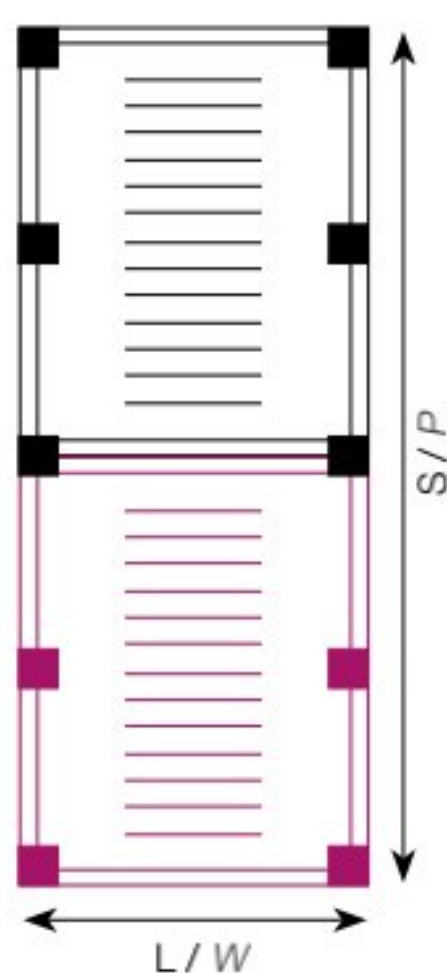

**MODULO DOPPIO  
ACCOPIATO IN PROFONDITÀ**  
Dimensioni massime: L 500 x S 2020

*DOUBLE MODULE  
COUPLED ON DEPTH SIDE*  
Max dimensions: W 500 x P 2020

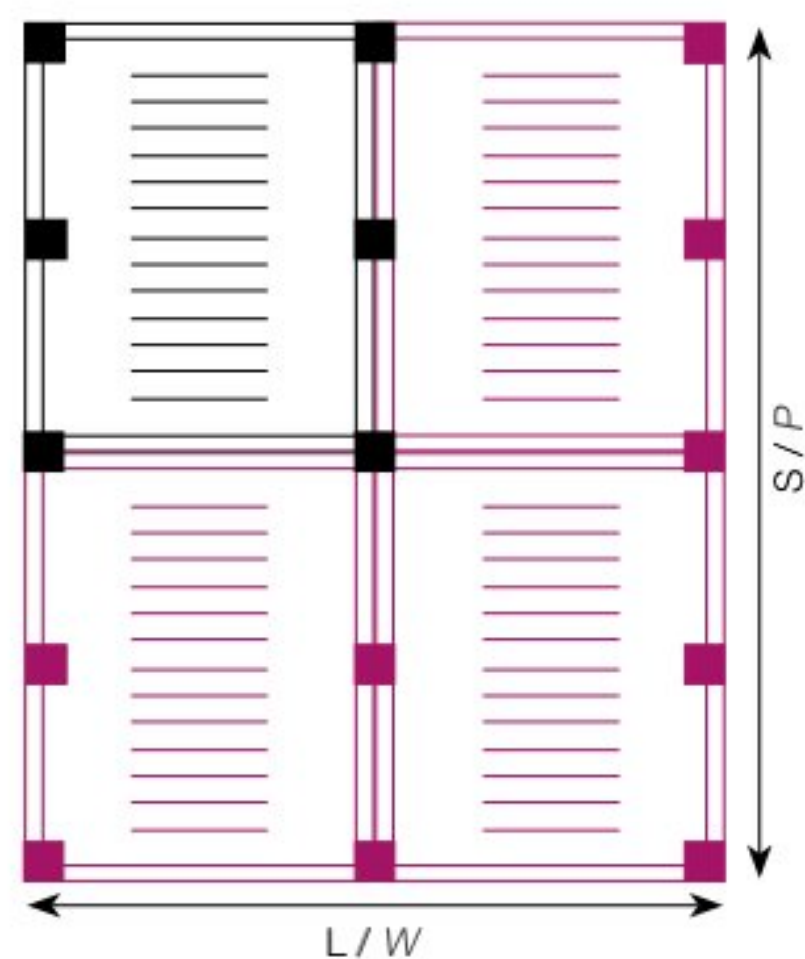

**MODULO QUADRUPLO  
ACCOPIATO IN PROFONDITÀ**  
Dimensioni massime: L 1000 x S 2020

*QUADRUPLE MODULE  
COUPLED ON DEPTH SIDE*  
Max dimensions: W 1000 x P 2020

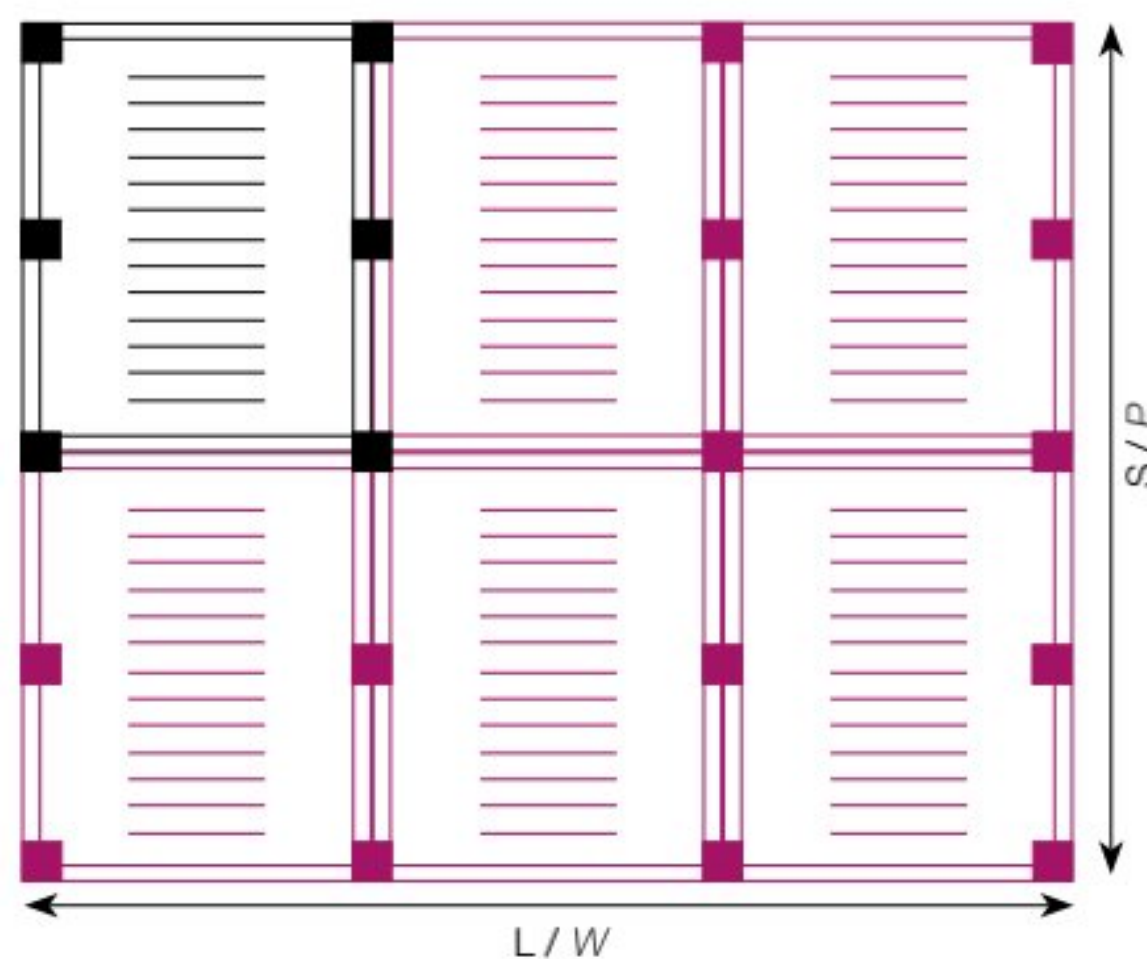

**MODULO SESTUPLO  
ACCOPIATO IN PROFONDITÀ**  
Dimensioni massime: L 1500 x S 2020

*SESTUPLE MODULE  
COUPLED ON DEPTH SIDE*  
Max dimensions: W 1500 x P 2020

**Resistenza al vento:**  
**UNI EN 13561.2015: classe 5**  
(corrispondente al grado 8 della scala Beaufort)

**Wind resistance:**  
**UNI EN 13561.2015: class 5**  
(corresponding to grade 8 of the Beaufort scale)

**Tenuta alla pioggia:**  
50 lt/ora per mq.

**Watertightness:**  
50 l/h per sqm.

**Carico accidentale di sicurezza:**  
fino a 50 kg. al mq.

**Accidental load safety:**  
up to kg. 50 per sqm.

**Orientamento lame:**  
140°

**Blades rotation:**  
140°

### verso di orientamento e adduzione elettrica / sunlight orientation and power supply

Luce diretta  
Direct light



Luce riflessa  
Reflected light

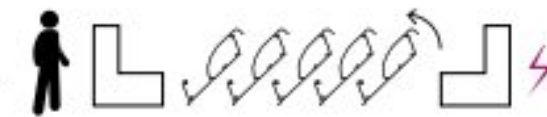

### Verso di orientamento luce diretta / Sunlight orientation direct light

Le lame si orientano verso il fascio di luce solare (proiezione diretta) ottenendo la massima luminosità della luce solare.  
The blades open towards the sunlight beam (direct projection) giving the maximum brightness of sunlight.

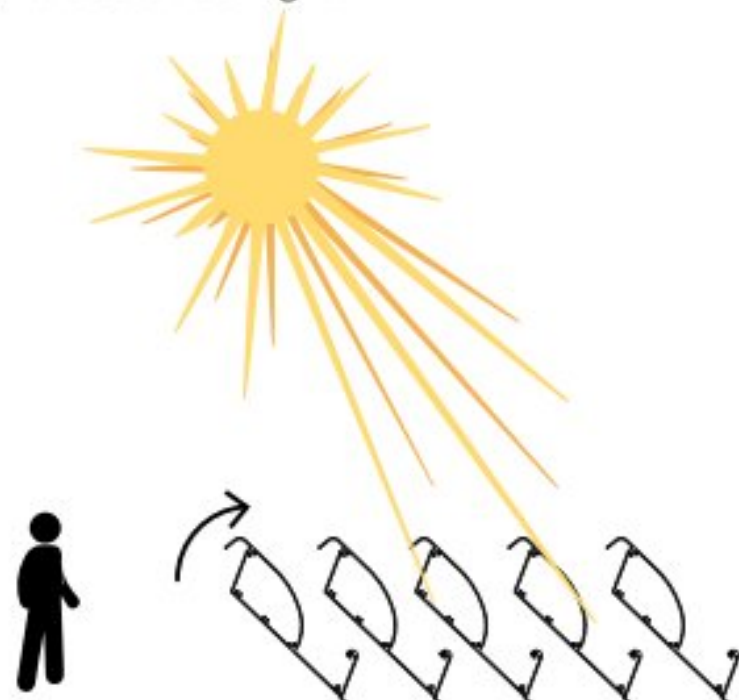

Vista frontale / Frontal view



### Verso di orientamento luce riflessa / Sunlight orientation reflected light

Le lame si orientano nel verso contrario al fascio di luce solare (proiezione indiretta) ottenendo maggiore protezione dalla luce solare.  
The blades are oriented in the opposite direction to the sunlight beam (indirect projection), providing greater protection from sunlight.



Vista laterale / Side view

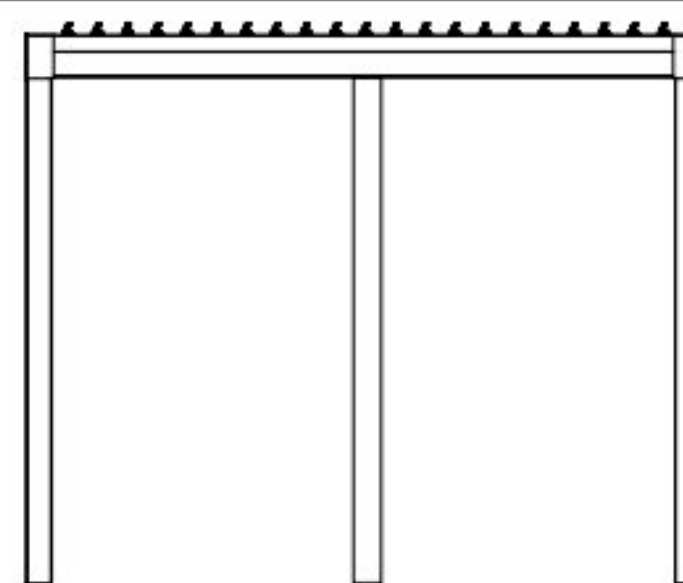

### Profili | Profiles

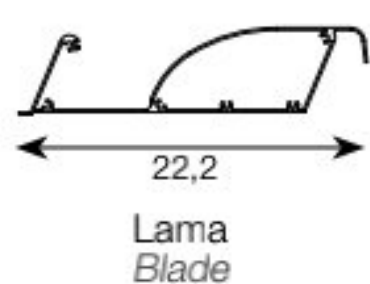

Lama  
Blade

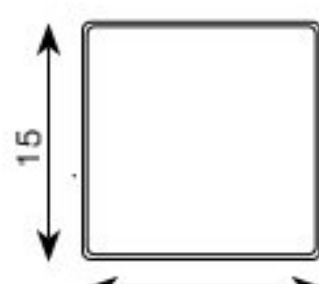

Piastro  
Pillar

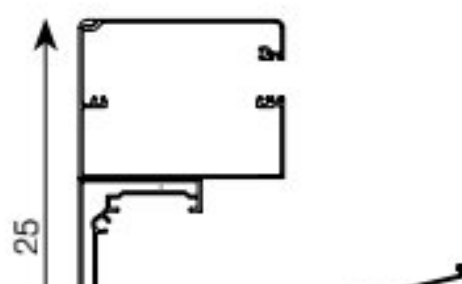

Gronda  
Gutter

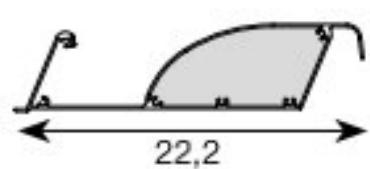

Lama SoundProof  
SoundProof blade

### Piastre | Floor plates

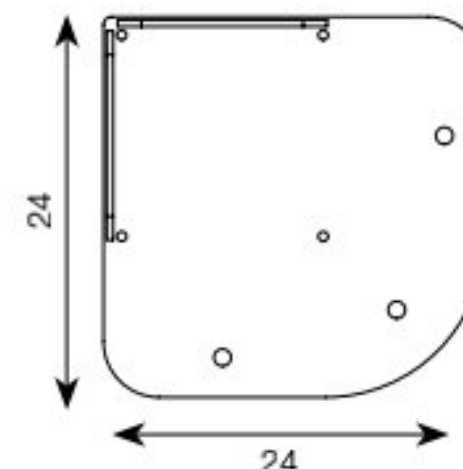

Piede Standard  
Standard foot

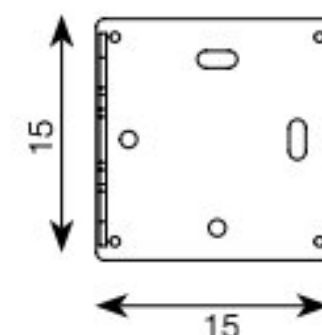

Piede a Scomparsa  
Hidden foot

## Sistemi di illuminazione | Lighting systems



OUTDOOR LED SYSTEM è l'impianto d'illuminazione a LED integrato nella pergola, rifinito con diffusore in policarbonato capace di offrire un flusso illuminante diffuso e uniforme di luce bianca calda o fredda gestita tramite radiocomando con dimmer.

OUTDOOR LED SYSTEM is the integrated LED system around the perimeter of the pergola, finished with polycarbonate diffuser for a constant luminous flux and unimodule light in white (warm/cold) operated by remote control with dimmer.



3000K

Lo spettro cromatico corrispondente alle varie temperature di colore.  
Visible spectrum of color temperatures.

### OUTDOOR LED SYSTEM 3000 K

Colore:	luce calda
Gradi Kelvin:	3000K
Lumen:	750 - 850 lumen/mt
Grado IP:	IP65
Potenza/Tensione:	9,6W/m ~ 24V

### OUTDOOR LED SYSTEM 3000 K

Color:	warm white
Degrees Kelvin:	3000K
Lumen:	750 - 850 lumen/mt
IP Rating:	IP65
Power/Voltage:	9,6W/m ~ 24V



OUTDOOR LED SYSTEM deve essere ordinato contestualmente alla pergola bioclimatica obbligatoriamente per tutte le gronde perimetrali.  
OUTDOOR LED SYSTEM must be ordered at the same time as the bioclimatic pergola.



OUTDOOR LED SYSTEM è l'impianto d'illuminazione a LED integrato nella pergola, rifinito con diffusore in policarbonato capace di offrire un flusso illuminante diffuso e uniforme di luce RGB gestita tramite radiocomando con dimmer.

OUTDOOR LED SYSTEM is the integrated LED system around the perimeter of the pergola, finished with polycarbonate diffuser for a luminous RGB LED light, operated by remote control with dimmer.

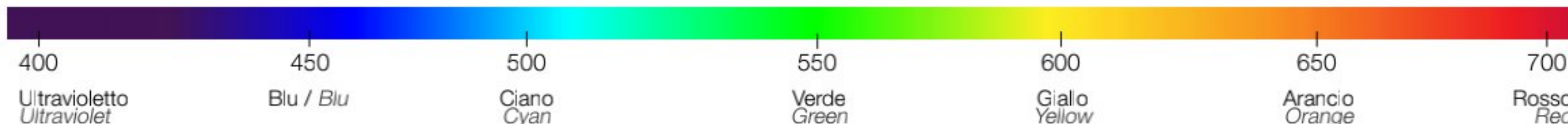

OUTDOOR LED SYSTEM RGB deve essere ordinato contestualmente alla pergola bioclimatica obbligatoriamente per tutte le gronde perimetrali.  
OUTDOOR LED SYSTEM RGB must be ordered at the same time as the bioclimatic pergola.

## SITUO 1 IO PURE II

Telecomando monocanale con funzione di comando individuale o di gruppo.  
Fornito con supporto a muro.  
*Single-channel remote control with individual or group control function. Supplied with wall support.*



## EOLIS WIREFREE IO - sensore vento EOLIS WIREFREE IO - wind sensor

Sensore Wirefree IO a batteria. Libertà di installazione in facciata.  
*Battery-powered Wirefree IO sensor. Freedom of installation in the facade.*



## SITUO 5 IO PURE II

Telecomando fino a 5 canali con funzione di comando decentralizzato e/o di gruppo.  
Fornito con supporto a muro.  
*5 channels remote control with local control or group control function. Supplied with wall support.*



## KIT CAPTATORE PIOGGIA RAIN SENSOR KIT

Kit corredato di captatore pioggia per il rilevamento delle precipitazioni, abbinato al trasmettitore wireless Izymo.  
*Kit equipped with rain sensor for rainfall detection, combined with wireless transmitter Izymo.*



## SITUO 5 VARIATION A/M IO PURE II

Telecomando fino a 5 canali con funzione di comando decentralizzato e/o di gruppo.  
Gestione colori RGB. Fornito con supporto a muro.  
*5 channels remote control with local control or group control function. RGB color control. Supplied with wall support.*



## TRASMETTITORE IMPIANTI DOMOTICI SMART HOME TRANSMITTER SYSTEMS

Trasmettitore Izimo IO - Homecontrol.  
*Transmitter Izimo IO - Homecontrol.*



## NINA

Telecomando touch screen multicanale per la gestione dei differenti dispositivi della casa  
Integrabile ai telecomandi Situo 1 IO e/o Situo 5 IO.  
*Multi-channel touch screen remote control and home automation for different devices management. Integrable with remote controls Situo 1 IO and / or Situo 5 IO*



## DOPPIO COMANDO DUAL CONTROL

Sistema di doppio comando per l'orientamento delle lame di un'unica pergola in due settori indipendenti.  
*Dual control blades tilting system of a single pergola in two independent sectors.*





## NOON

Telecomando portatile o a parete (9 canali, 63 funzioni).  
Può gestire fino a 9 funzioni differenti tra  
lame, LED (bianchi o RGB) e sistema audio integrato.  
*Portable remote control equipped with wallmounting  
clip (9 channels, 63 different functions).  
It can manage up to 9 different functions i.e. blades,  
LED (white or RGB) and integrated audio system.*



## CAPTATORE PIOGGIA RAIN 103 WIRELESS WIRELESS RAIN SENSOR 103

Captatore pioggia wireless per il rilevamento delle  
precipitazioni, abbinato al trasformatore.  
*Kit with wireless rain sensor to detect rain  
to be combined with power transformer.*



## CENTRALINA DAISY + APP CONTROL UNIT DAISY + APP



Centralina per App Wi-Fi innovativa e versatile da  
Smartphone e Tablet attivazione di tutte le automazioni  
installate.

L'App dà la possibilità di accendere e spegnere in  
modo automatico o manuale l'illuminazione, regolarne  
l'intensità e creare molteplici scenari.

*Innovative and versatile Wi-Fi interface App for  
Smartphone and Tablet activation of all installed  
automations.*

*The App gives the option of switching the lighting on  
and off automatically or manually, dimming the intensity  
of the light and creating multiple scenarios.*



Altri sensori e ricevitori a preventivo.  
*Other sensors and receivers on request.*



## TRASMETTITORE PER IMPIANTI DOMOTICI TRANSMITTER FOR SMART HOME AUTOMATION

Trasmettitore radio per impianti domotici 2 / 3 / 4 canali.  
*Radio transmitter for home automation systems 2 / 3 / 4  
channels.*



## DIRELLO CONCERT

Sistema audio integrato, con tecnologia Bluetooth.  
Corredato di centrale, alimentatore e n° 2 speaker da  
incasso, abbinato a trasmettitore NOON  
Potenza acustica 25W cad.

*Integrated sound system with Bluetooth wireless  
technology.*

*Supplied with central unit, power supply and 2 built-in  
speakers, combined with NOON transmitter.*

*Acoustic power 25W each.*

**\*Dirello Concert è integrabile nelle  
pergole previste di pilastri.  
\*Dirello Concert can be integrated only  
on pergolas with pillars**



## Palette Colori Ral | Colors Palette Ral

### La verniciatura a polveri dei nostri profili si suddivide sostanzialmente in tre cicli:

- > pretrattamento chimico applicato sul profilo grezzo per ottenere finiture perfette e durevoli nel tempo;
- > applicazione della polvere poliesteri mediante pistole elettrostatiche automatiche;
- > polimerizzazione a 200° per ottenere un rivestimento finale resistente aumentando le caratteristiche meccaniche del profilo stesso.

### The powder coating of our profiles is basically divided into three cycles:

- > chemical pre-treatment applied on the raw profile to obtain perfect and long-lasting finishes;
- > application of polyester powder using automatic electrostatic guns;
- > curing conditions at 200° to obtain an extra strong final coating, increasing the mechanical characteristics of the profile itself.

### COLORI STRUTTURA | COLORS STRUCTURE

 <p><b>RAL 9010</b> Bianco Puro Ruvido <i>Fine txt. Pure White</i> Gtot 0,06 Classe 4   Class 4</p>	 <p><b>RAL 1013</b> Avorio Ruvido <i>Fine txt. Ivory</i> Gtot 0,06 Classe 4   Class 4</p>	 <p><b>F235</b> Corten Punt. Ruvido <i>Dotten Corten</i> Gtot 0,06 Classe 4   Class 4</p>	 <p><b>F213</b> Grigio Ferro Ruvido <i>Fine txt. Iron Grey</i> Gtot 0,16 Classe 2   Class 2</p>	 <p><b>RAL 7006</b> Grigio Beige Ruvido <i>Fine txt. Beige Grey</i> Gtot 0,10 Classe 3   Class 3</p>	 <p><b>RAL 7001</b> Grigio Argento Ruv. <i>Fine txt. Silver Grey</i> Gtot 0,09 Classe 4   Class 4</p>
--	--	--	--	---	--

Possibilità di ordinare strutture bicolore unicamente per i colori sopra elencati | Two-tone structures can be ordered for the above colors

### \*COLORI DI TENDENZA | \*TREND COLORS

 <p><b>RAL 1019</b> Beige Ruvido <i>Fine txt. Beige</i> Gtot 0,10 Classe 3   Class 3</p>	 <p><b>RAL 7034</b> Grigio Giallo Ruvido <i>Fine txt. Yellow Grey</i> Gtot 0,06 Classe 4   Class 4</p>	 <p><b>RAL 6003</b> Verde Oliva Ruvido <i>Fine txt. Olive Green</i> Gtot 0,09 Classe 4   Class 4</p>	 <p><b>RAL 6005</b> Verde Muschio Ruvido <i>Fine txt. Moss Green</i> Gtot 0,09 Classe 4   Class 4</p>	 <p><b>RAL 7039</b> Grigio Quarzo Ruvido <i>Fine txt. Quarz Grey</i> Gtot 0,12 Classe 3   Class 3</p>	 <p><b>RAL 8014</b> Marrone Seppia Ruv. <i>Fine txt. Sepia Brown</i> Gtot 0,06 Classe 4   Class 4</p>
 <p><b>RAL 8019</b> Marrone Grigio Ruv. <i>Fine txt. Brown Grey</i> Gtot 0,06 Classe 4   Class 4</p>	 <p><b>F206</b> Marrone Cuoio Ruv. <i>Fine txt. Leat. Brown</i> Gtot 0,06 Classe 4   Class 4</p>	 <p><b>RAL 7035</b> Grigio Luce Ruvido <i>Fine txt. Light Grey</i> Gtot 0,09 Classe 4   Class 4</p>	 <p><b>RAL 9006</b> Alluminio Met. Opaco <i>Matt Met. Aluminium</i> Gtot 0,06 Classe 4   Class 4</p>	 <p><b>RAL 7037</b> Grigio Polvere Ruvido <i>Fine tex. Powder Grey</i> Gtot 0,12 Classe 3   Class 3</p>	 <p><b>RAL 7016</b> Grigio Antracite Ruv. <i>Fine txt. Anthr. Grey</i> Gtot 0,16 Classe 2   Class 2</p>

\*Verniciature con costi supplementari | \*Coating with additional charge

### COLORI PARTI IN NYLON | NYLON COLORS PARTS

 <p>Bianco <i>White</i> RAL 9010</p>	 <p>Avorio <i>Ivory</i> RAL 1013 RAL 1019</p>	 <p>Grigio Ferro <i>Iron Grey</i> F213 RAL 7016</p>	 <p>Grigio <i>Grey</i> RAL 7001 RAL 7035 RAL 9006 RAL 7037 RAL 7039</p>	 <p>Tortora <i>Taupe</i> RAL 7006</p>	 <p>Corten F235</p>	 <p>Verde <i>Green</i> RAL 7034 RAL 6003 RAL 6005</p>	 <p>Marrone <i>Brown</i> RAL 8014 RAL 8019 F206</p>
---	--	--	---	--	--	--	--

Le riproduzioni dei colori delle vernici sono da ritenersi indicative | The coatings colors reproductions can be considered as purely indicative