

— • ≡ S S ≡ N Z I A L E ≡

L E S S .  
*is more*

---

Il principio delle forme, del design, dei materiali e della luce. *'Less is more'* è una filosofia che viene applicata alla vita ma anche alle forme architettoniche, con la finalità di raggiungere la massima funzionalità e semplicità delle linee, senza aggiungere nulla di più. *'Less is more'* è anche uno stile deciso, dato dall'animo contrastato della porta in vetro: unisce l'ambiente e allo stesso tempo separa gli spazi, resiste al dinamismo

*The concept of shapes, design, materials and light.*  
*'Less is more' is a philosophy applied to life but also to the architectural shapes, aimed to achieve the maximum functionality and simplicity of lines, without adding anything else.*  
*'Less is more' is also a resolute style, given by the contrasting glass door core: it joins the room while separating space, resisting daily dynamics while remaining lightweight, its matter does not hinder but illuminates*

quotidiano restando leggera, la sua materialità non ostacola ma illumina e le sue linee minimal arricchiscono senza togliere nulla all'ambiente. Ad ogni ora la casa si arricchisce di una luce nuova svelando la bellezza degli spazi. Il passaggio dalla luce calda del mattino, fino alla luce fioca della sera, viene visto attraverso il vetro, a volte trasparente, altre satinato, ma sempre essenziale. Il mutare della luce l'abbiamo riprodotto nel catalogo per raccontare la storia della casa.

*and its minimal lines enrich without taking away from the room. The home is embellished by a new light revealing the beauty of its space any time of day. The shift from the warm morning light to the dim evening light is seen through the glass, at times transparent, others frosted, but always essential. We reproduced the changing light in the catalogue to tell the story of the home.*

6

8

46

48

50

60

66

**Descrizione linea**  
*Line description*

**Mono**  
*Mono*

**Dettagli tecnici**  
*Technical details*

**Modelli**  
*Models*

**Finiture**  
*Finishes*

**Disegni tecnici**  
*Technical draws*

**Maniglie**  
*Handles*

7

68

90

92

96

102

**Descrizione linea**  
*Line description*

**Duo**  
*Duo*

**Dettagli tecnici**  
*Technical details*

**Finiture**  
*Finishes*

**Disegni tecnici**  
*Technical draws*

**Maniglie**  
*Handles*



#### IMMAGINE ANAMORFICA

Appoggia il catalogo su una superficie e inquadra con la camera, del tuo smartphone o tablet, per vedere l'immagine in 3D

#### ANAMORPHIC IMAGE

Rest the catalogue on a flat surface and observe it through a camera lens, your smartphone or tablet to see the image in 3D



## MONO

Collezione di porte a vetro singolo, ad una o più ante.  
Il vetro temperato è disponibile con uno spessore da 8 mm o 4+4 mm, può essere personalizzato con varie soluzioni cromatiche e con lavorazioni di sabbiatura, incisione e stampa digitale.  
Le versioni realizzabili sono: battente, battente minimale, scorrevole a scomparsa, scorrevole essential, scorrevole esterno, scorrevole Zero, Pivot, pieghevole a 2, 3 o 4 ante.

Tutti i vetri sono certificati secondo le normative di sicurezza UNI 7697 e UNI EN 12600.

*Single glass door collection with one or more leaves.  
The tempered glass is available with thickness from 8 mm or 4+4 mm, it can be customised with various colour solutions and sanded, engraved or digital print finish.  
Available versions include: hinged, minimal hinged, pocket sliding, essential sliding, external sliding  
Zero sliding, Pivot, folding with 2, 3 or 4 leaves.*

*All glass is certified according to UNI 7697 and UNI EN 12600 safety regulations.*

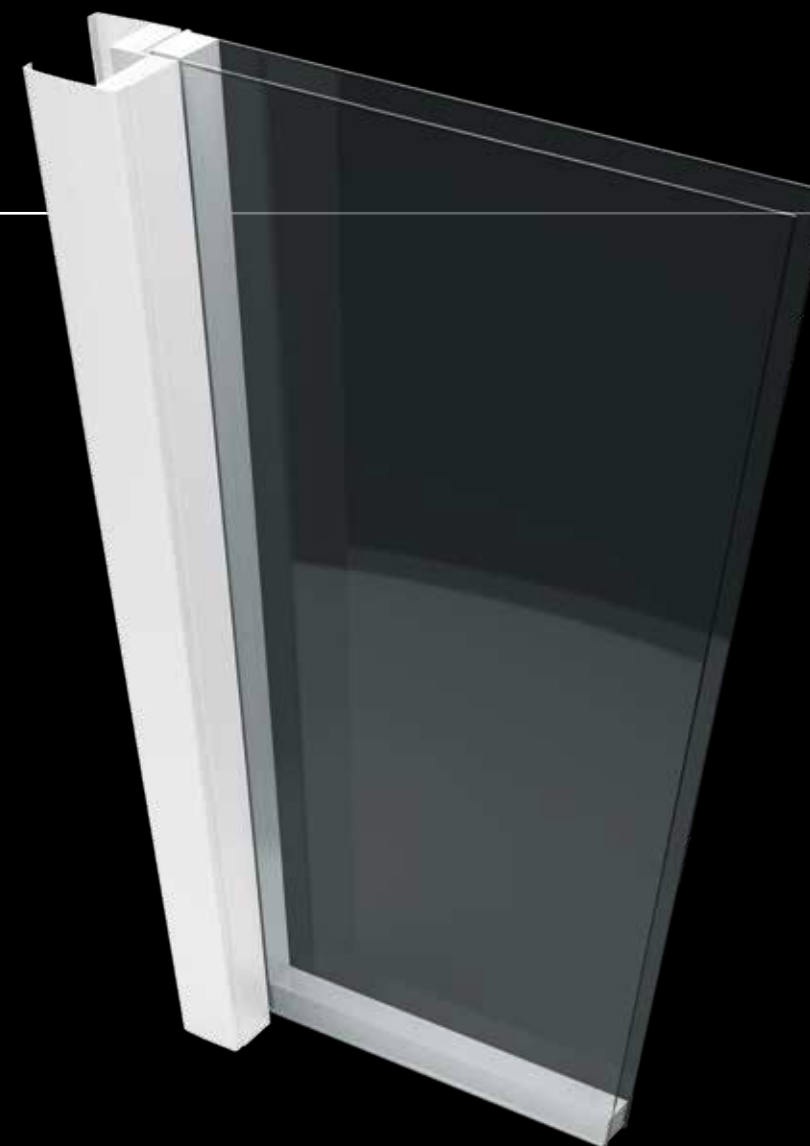

## DUO

Collezione di porte a vetro doppio, ad una o più ante.  
Il vetro temperato è di spessore 5 mm, per le porte a battente si possono raggiungere i 240 cm di altezza, mentre per le scorrevoli si arriva fino a 270 cm. Oltre a porta a battente, scorrevole a scomparsa e varie tipologie di scorrevoli esterni è disponibile anche la versione pieghevole a 2 o 3 ante.

Tutti i vetri sono certificati secondo le normative di sicurezza UNI 7697 e UNI EN 12600.

*Double glass door collection with one or more leaves.  
The tempered glass is available with 5 mm thickness, for hinged doors it can reach 240 cm in height, while for sliding doors it can reach up to 270 cm. In addition to hinged, pocket sliding and various types of external sliding the folding version with 2 or 3 leaves is also available.*

*All glass is certified according to UNI 7697 and UNI EN 12600 safety regulations.*

# MONO

---

Uno, come il vetro singolo che riesce ad illuminare un ambiente intero. Quando la leggerezza diventa l'elemento fondamentale in un ambiente, si ha il raggiungimento del benessere e della stabilità. **S-nziale Mono** è lo stile che supera le forme e abbraccia la personalizzazione delle incisioni e dei decori, in un'unica superficie.

*One, like the single glass that can illuminate the entire room. Wellness and stability can be achieved when levity becomes a fundamental element in a room. **S-nziale Mono** is the style that exceeds shapes and embraces the customisation of the engravings and decorations in a single surface.*

S00

**Battente TRATTO**  
Alluminio: argento  
Vetro: laccato rosso

*TRATTO hinged*  
Aluminium: silver  
Glass: red lacquered



## S00

**Battente MINIMALE**  
Alluminio: nero  
Vetro: sfumato nero

*MINIMALE hinged*  
Aluminium: black  
Glass: shaded black



## S00

### Scorrevole a scomparsa

Alluminio: testa di moro  
Vetro: mod. Segni  
deco trasparente bronzo  
su fondo sabbiato

### Pocket sliding

Aluminium: dark brown  
Glass: mod. Segni  
transparent bronze  
decoration on sanded  
background





### S00

**Scorrevole esterno**  
Alluminio: bianco  
Vetro: mod. Viaggio sabbia  
deco trasparente su  
fondo sabbato

*External sliding*  
Aluminium: white  
Glass: mod. Viaggio sabbia  
transparent decoration on  
sanded background



### S00

**Scorrevole esterno muro  
binario incassato**  
Alluminio: argento  
Vetro: mod. Africa  
su fondo acidato

*Wall-mounted recessed track  
external sliding*  
Aluminium: silver  
Glass: mod. Africa  
on frosted background

**S00**

**Libro simmetrica  
doppia anta**  
Alluminio: nero  
Vetro: trasparente

*Symmetrical folding  
double leaf*  
Aluminium: black  
Glass: transparent





#### S00

**Battente TRATTO**  
Alluminio: argento  
Vetro: mod. Link  
decoro trasparente  
su fondo sabbiato

*TRATTO hinged*  
Aluminium: silver  
Glass: mod. Link  
transparent decoration  
on sanded background

#### SN00

**Battente TRATTO**  
Alluminio: argento  
Anta: laccato bianco  
ral 9016

*TRATTO hinged*  
Aluminium: silver  
Leaf: white lacquered  
ral 9016

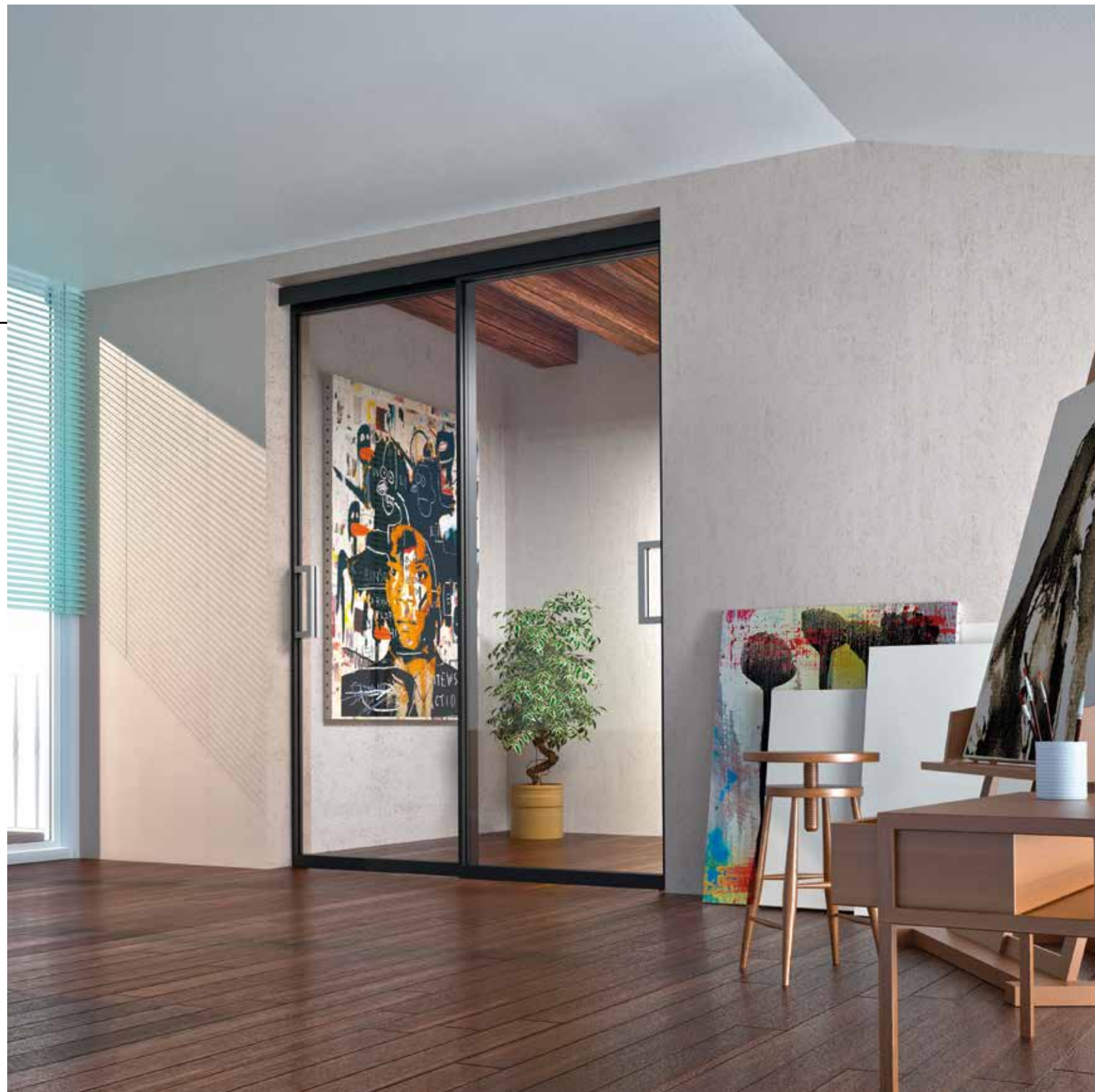

**S00** Scorrevole parallelo interno / Alluminio: nero / Vetro: trasparente  
*Parallel internal sliding / Aluminium: black / Glass: transparent*

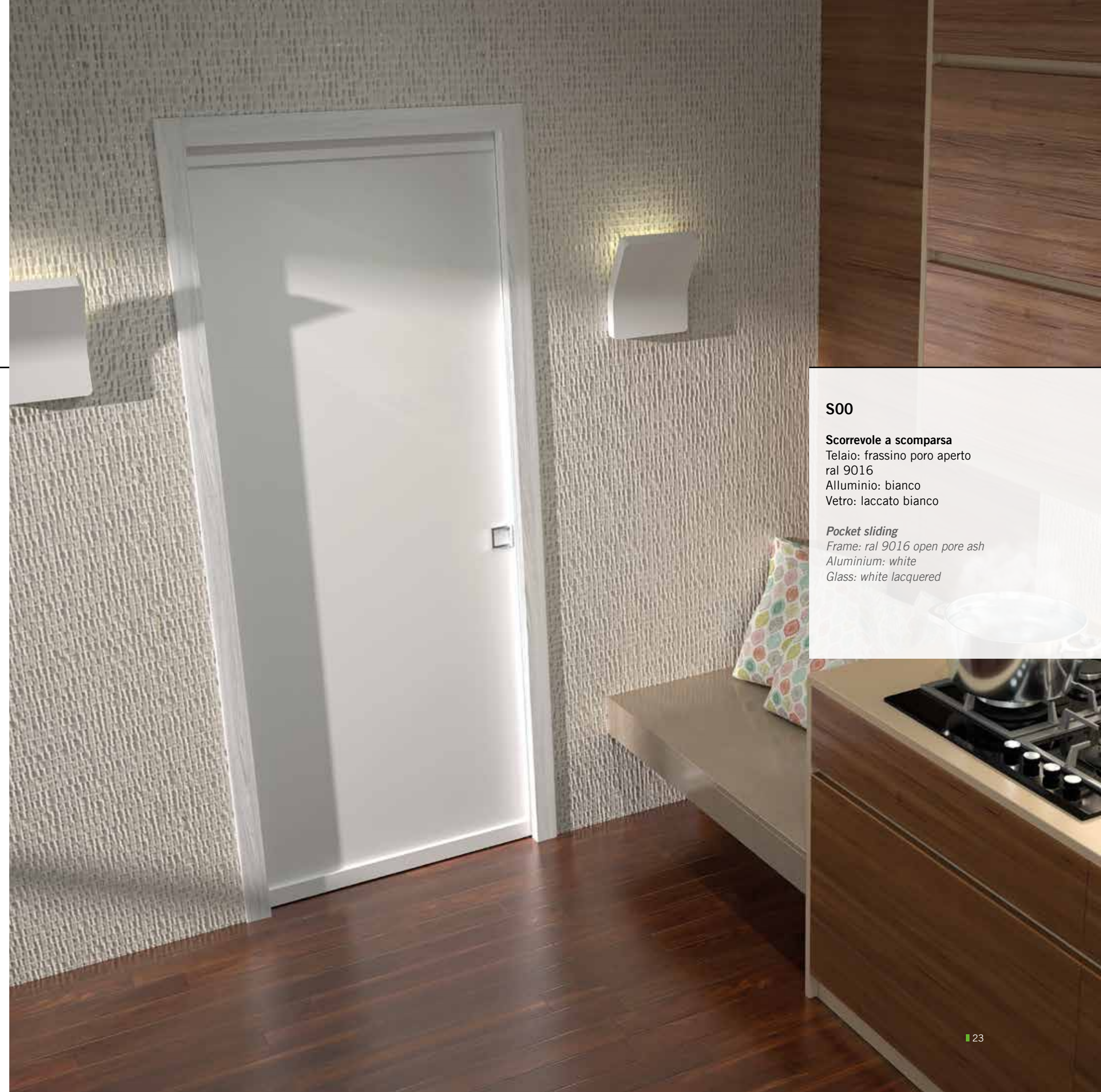

**S00**

**Scorrevole a scomparsa**  
Telaio: frassino poro aperto  
ral 9016  
Alluminio: bianco  
Vetro: laccato bianco

**Pocket sliding**  
Frame: ral 9016 open pore ash  
Aluminium: white  
Glass: white lacquered

**S00**

**Battente MINIMALE**  
Alluminio: argento  
Vetro: tessuto bianco

*MINIMALE hinged*  
Aluminium: silver  
Glass: white cloth





## S00

**Scorrevole esterno  
attacco a soffitto**  
Alluminio: testa di moro  
Vetro: trasparente

**Porta NS05**  
frassino poro aperto ral 9016

*Ceiling mounted  
external sliding  
Aluminium: dark brown  
Glass: transparent*

**Door NS05**  
ral 9016 open pore ash



## S00

**Battente MINIMALE**  
Alluminio: argento  
Vetro: trasparente rosso

**MINIMALE hinged**  
Aluminium: silver  
Glass: transparent red



## S00

### Scorrevole ESSENTIAL

Alluminio: ral 5012  
Vetro: stampa digitale  
mod. Hippy porpora  
su acidato

### ESSENTIAL sliding

Aluminium: ral 5012  
Glass: mod. Hippy digital  
print purple on frosted





## S00

**Scorrevole a scomparsa**  
Alluminio: testa di moro  
Vetro: mod. Canne scavo

*Pocket sliding*  
Aluminium: dark brown  
Glass: mod. Cane hollow



## S00

**Battente TRATTO**  
Alluminio: testa di moro  
Vetro: stampa digitale  
mod. Gran dama caffè  
su acidato

*TRATTO hinged*  
Aluminium: dark brown  
Glass: mod. Gran dama  
coffee digital print on frosted

## SN00

### Battente

Anta: laccata ral 1019  
Telaio: laccato ral 1019

### Hinged

Leaf: ral 1019 lacquered  
Frame: ral 1019 lacquered

## S02

### Scorrevole esterna attacco a parete

Mantovana: laccata ral 1019  
Bordo anta: argento  
2 vetri acidati  
1 vetro trasparente

### Wall mounted external sliding

ral 1019 lacquered pelmet  
Silver leaf edge  
2 frosted glasses  
1 transparent glass

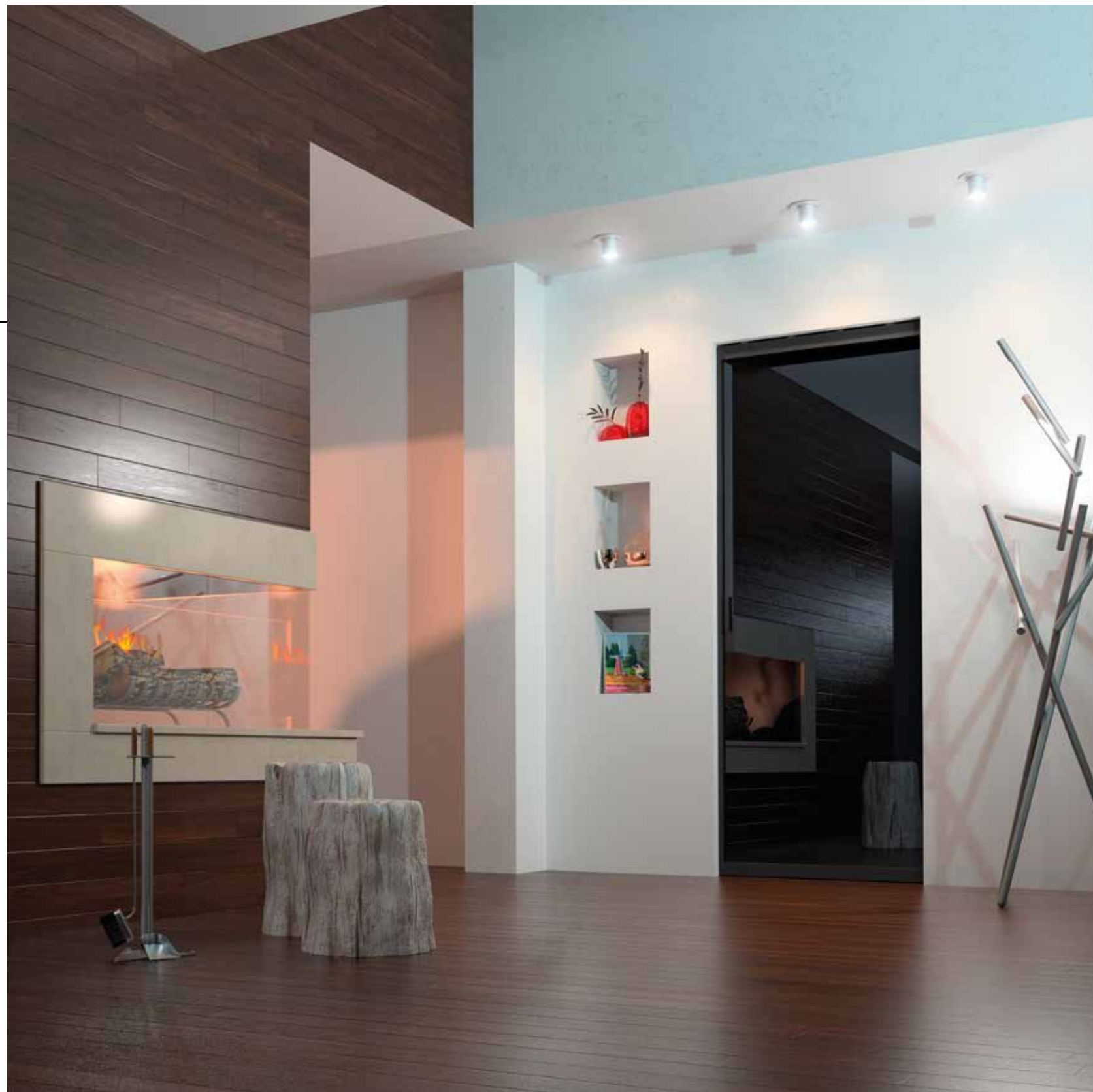

**S00** Scorrevole esterno binario incassato / Alluminio: nero / Vetro: laccato nero lucido  
Recessed track external sliding / Aluminium: black / Glass: glossy black lacquered

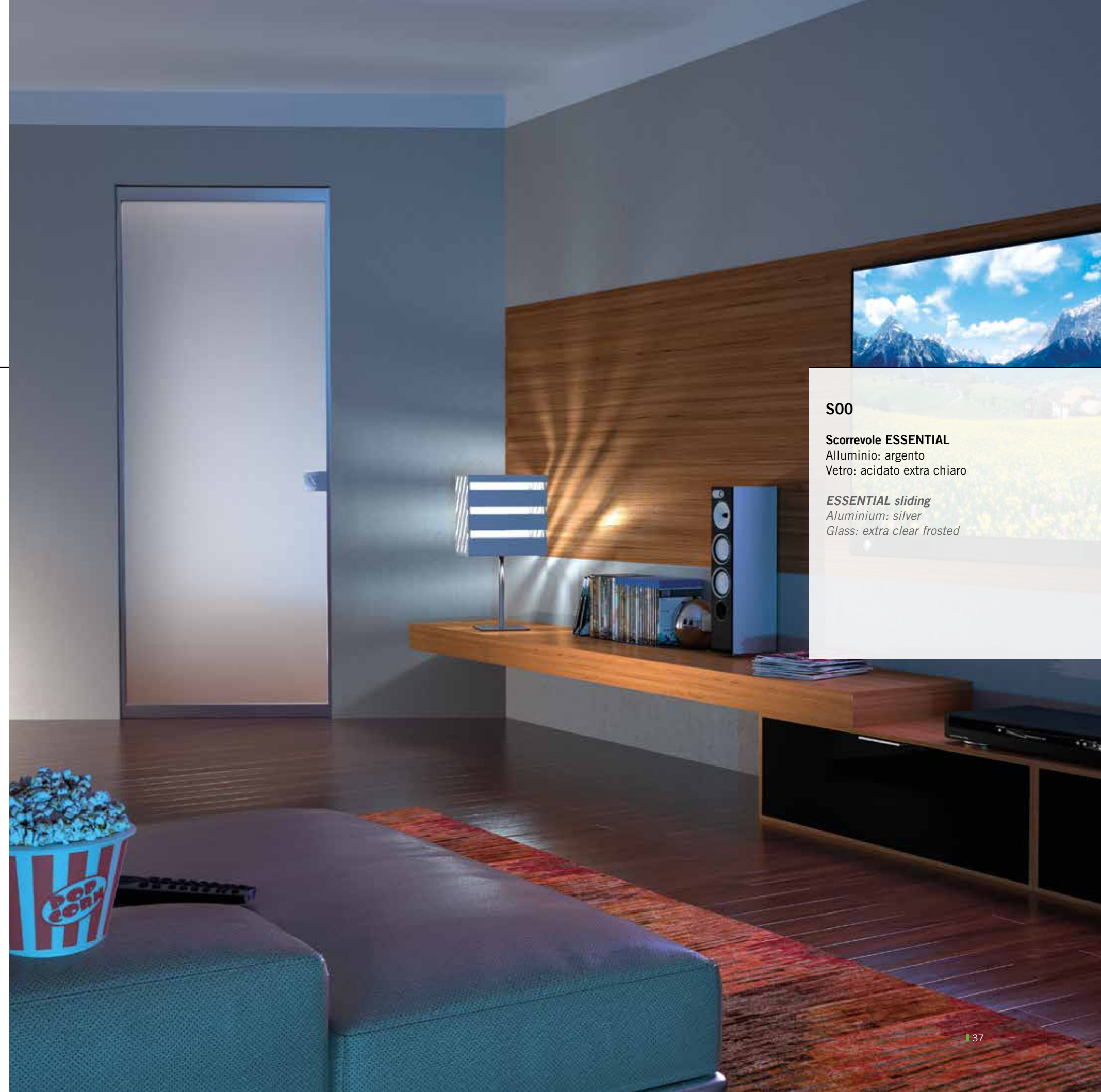

**S00**

**Scorrevole ESSENTIAL**  
Alluminio: argento  
Vetro: acidato extra chiaro

*ESSENTIAL sliding*  
Aluminium: silver  
Glass: extra clear frosted



### S00

**Battente TRATTO**  
Alluminio: bianco  
Vetro: mod. Tratto  
nero su acidato

*TRATTO hinged*  
Aluminium: white  
Glass: mod. Tratto  
black on frosted

## S00

### Battente MINIMALE

Alluminio: argento  
Vetro: mod. Anthea  
doppia sabbatura  
trasparente grigio

*MINIMALE hinged*  
Aluminium: silver  
Glass: mod. Anthea  
double grey transparent  
sandblasting





## S00

**Scorrevole ESSENTIAL**  
Alluminio: testa di moro  
Vetro: mod. Fiori  
decoro trasparente  
su fondo sabbiato

*ESSENTIAL sliding*  
Aluminium: dark brown  
Glass: mod. Fiori  
transparent decoration  
on sanded background

## S10

**Scorrevole parallelo  
interno 3 ante**  
Alluminio: nero  
Vetro: trasparente

*Parallel internal  
sliding 3 leafs*  
Aluminium: black  
Glass: transparent

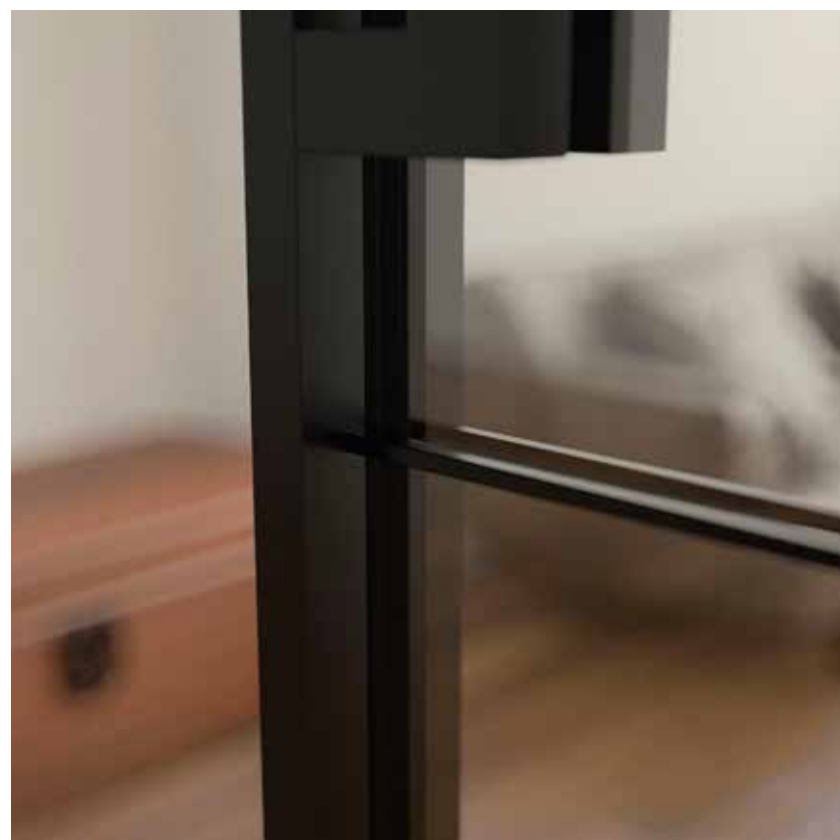



# MONO

## DETTAGLI TECNICI TECHNICAL DETAILS

La linea **S-nziale Mono** è realizzata con un singolo vetro temperato, è disponibile nella versione stratificata con lo spessore di 4+4 mm o su lastra monolitica con lo spessore di 8 mm. In entrambi i casi la struttura è realizzata in alluminio anodizzato o verniciato, con una sezione di 40x16 mm (44x40 mm per i soli traversi orizzontali su porte scorrevoli).

*The S-nziale Mono line is made of a single tempered glass, available in the layered version with 4+4 mm thickness or on a single slab with 8 mm thickness. In both cases, the frame is made of anodised or painted aluminium, with a 40x16 mm section (44x40 mm for the sole horizontal beams on sliding doors).*

# MODELLI

MODELS

---

- 1. S00  
S00
- 2. S01  
S01
- 3. S02  
S02
- 4. S03  
S03
- 5. S04  
S04
- 6. S06  
S06
- 7. S08  
S08
- 8. S10  
S10

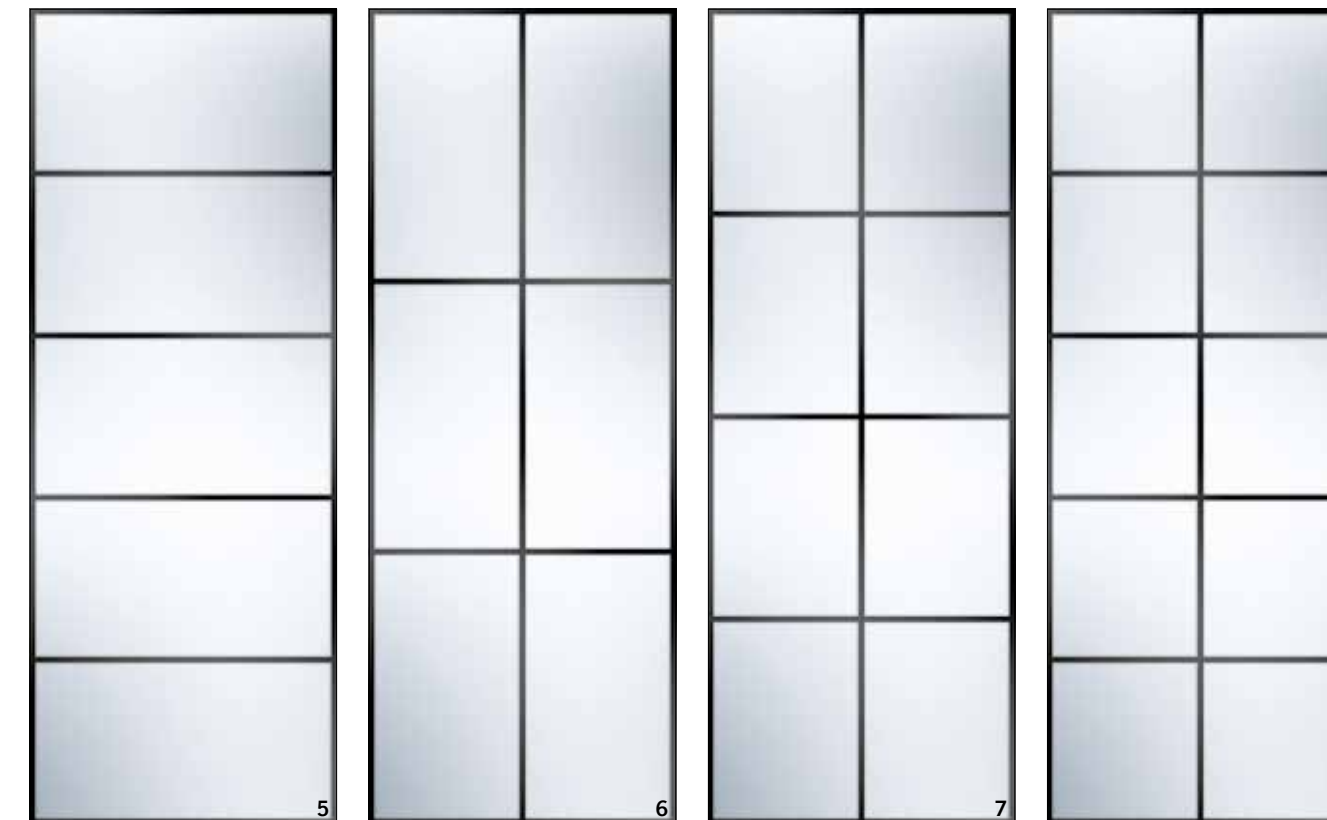
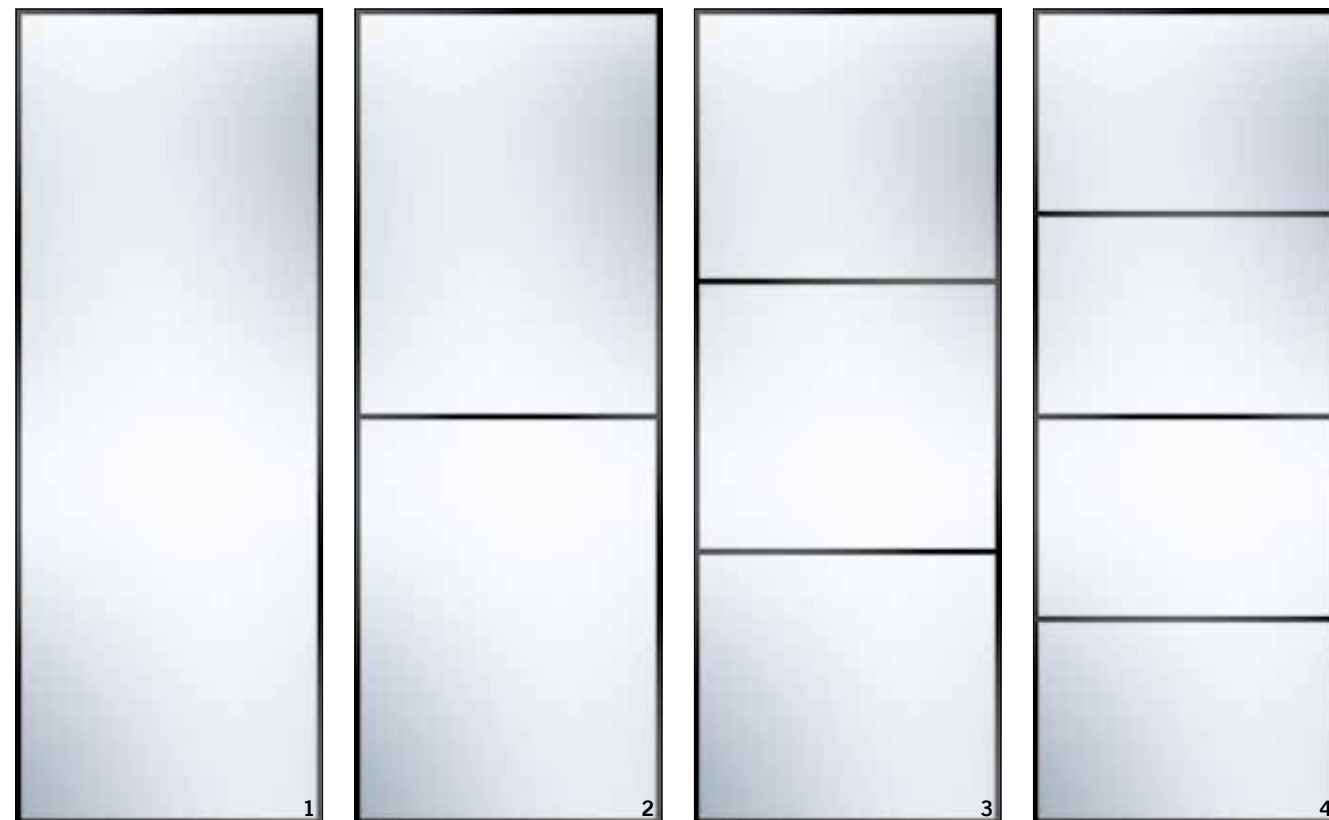

# FINITURE

## FINISHES

---

### ALLUMINIO ALUMINIUM

1. Argento  
*Silver*
2. Bianco  
*White*
3. Nero  
*Black*
4. Testa di moro  
*Dark brown*

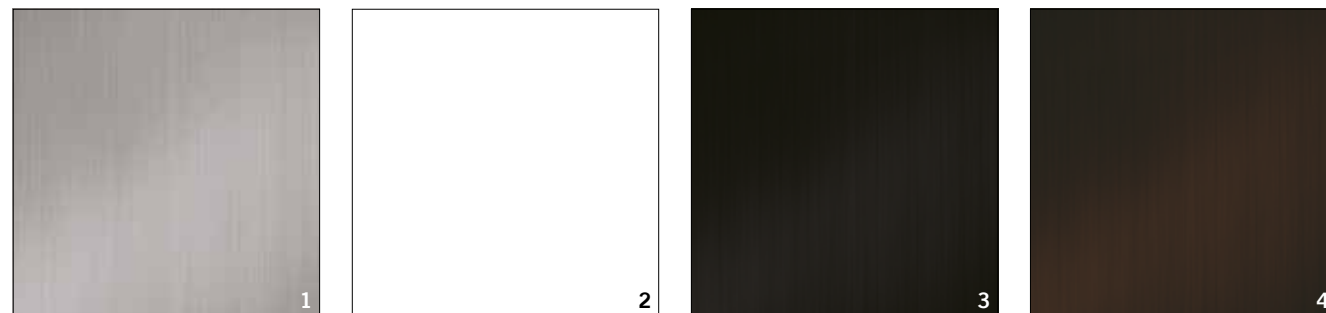

### VETRI TRASPARENTI TRANSPARENT GLASS

1. Trasparente  
*Transparent*
2. Trasparente extra chiaro  
*Extra clear transparent*
3. Trasparente bronzo  
*Transparent bronze*
4. Trasparente grigio  
*Transparent grey*
5. Trasparente arancio  
*Transparent orange*
6. Trasparente porpora  
*Transparent purple*
7. Trasparente rosso  
*Transparent red*
8. Trasparente blu  
*Transparent blue*
9. Semiriflettente grigio  
*Semi-reflective grey*

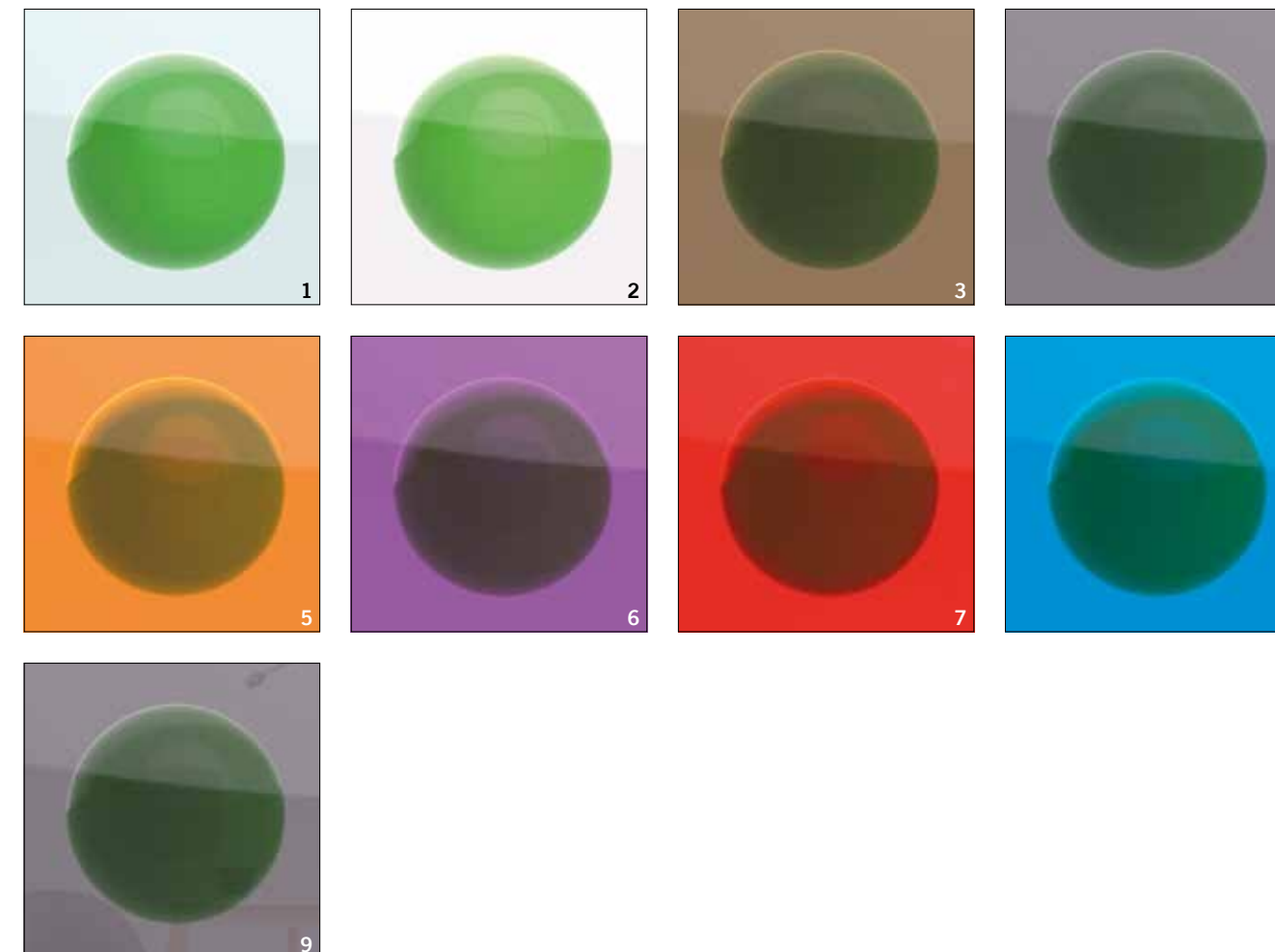

**VETRI ACIDATI**  
*FROSTED GLASS*

1. Acidato  
*Frosted*
2. Acidato extra chiaro  
*Extra clear frosted*
3. Acidato bronzo  
*Frosted bronze*
4. Acidato grigio  
*Frosted grey*
5. Acidato arancio  
*Frosted orange*
6. Acidato porpora  
*Frosted purple*
7. Acidato rosso  
*Frosted red*
8. Acidato blu  
*Frosted blue*

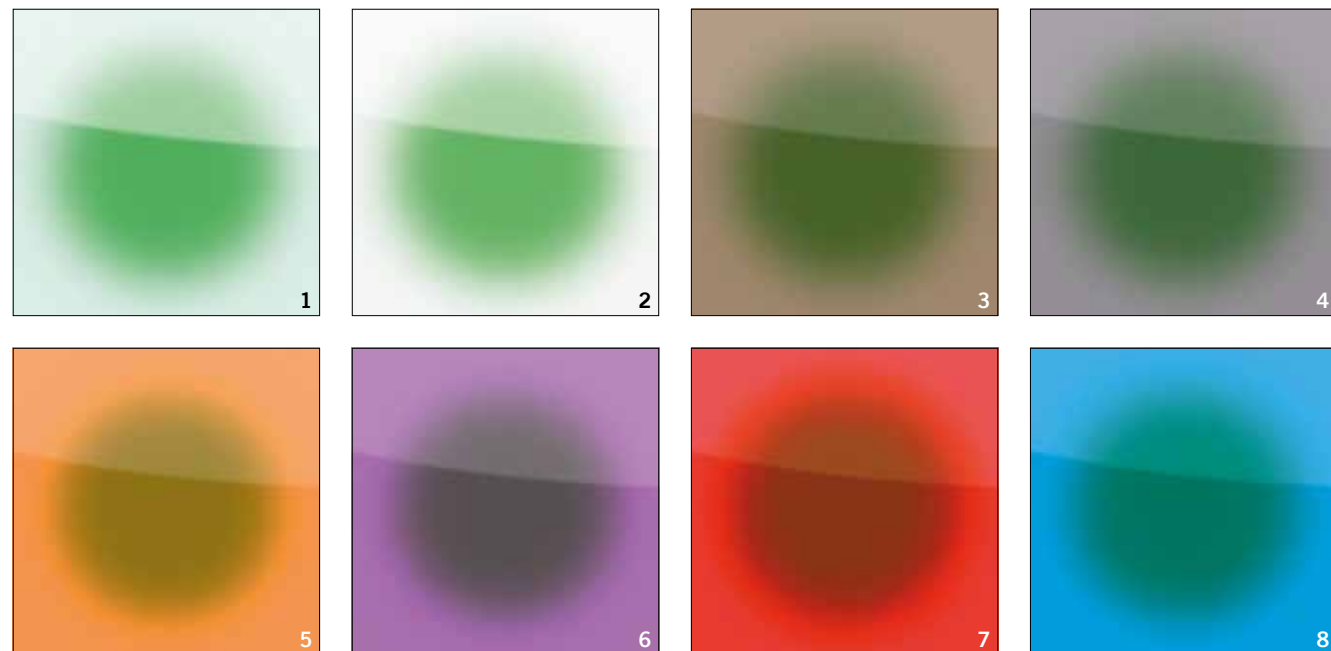

**VETRI SFUMATI**  
*SHADED GLASS*

1. Sfumato nero  
*Shaded black*
2. Sfumato viola  
*Shaded violet*
3. Sfumato caffè  
*Shaded coffee*
4. Sfumato rosso  
*Shaded red*

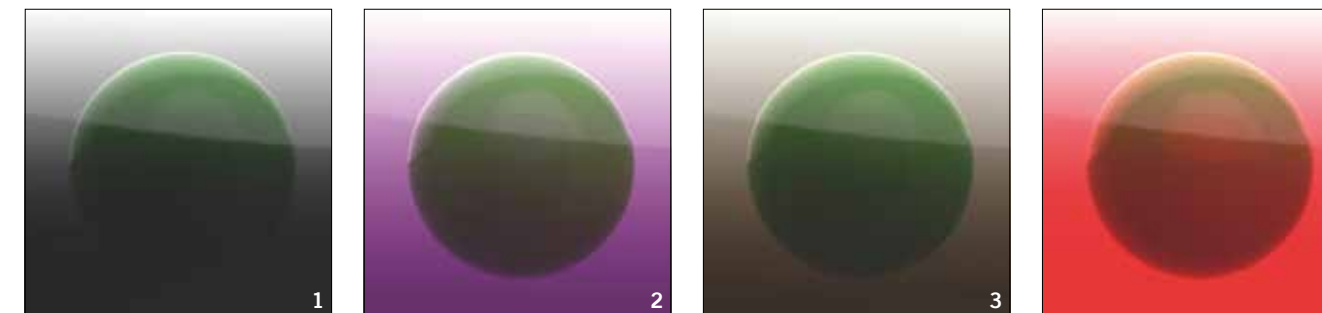

**VETRI LACCATI**  
*LACQUERED GLASS*

1. Laccato bianco  
*White lacquered*
2. Laccato nero  
*Black lacquered*
3. Laccato rosso  
*Red lacquered*



**VETRI TESSUTI**  
*CLOTH GLASS*

1. Tessuto bianco  
*White cloth*
2. Tessuto nero  
*Black cloth*
3. Tessuto naturale  
*Natural cloth*



**VETRI SABBIA**  
SABBIA GLASS

1. Africa  
*Africa*
2. Messico  
*Messico*
3. Fiori  
*Fiori*
4. Klimt sabbia  
*Klimt sabbia*
5. Viaggio sabbia  
*Viaggio sabbia*
6. Gran dama  
*Gran dama*
7. Hippy  
*Hippy*
8. Link  
*Link*
9. Tela  
*Tela*
10. Segni  
*Segni*
11. Albero sabbia  
*Albero sabbia*
12. Albero sabbia  
seconda anta  
*Albero sabbia  
second leaf*



**VETRI SCAVO**  
HOLLOW GLASS

1. Canne  
*Canne*
2. Oriente  
*Oriente*
3. Klimt  
*Klimt*
4. Viaggio  
*Viaggio*
5. Albero  
*Albero*
6. Albero seconda anta  
*Albero second leaf*

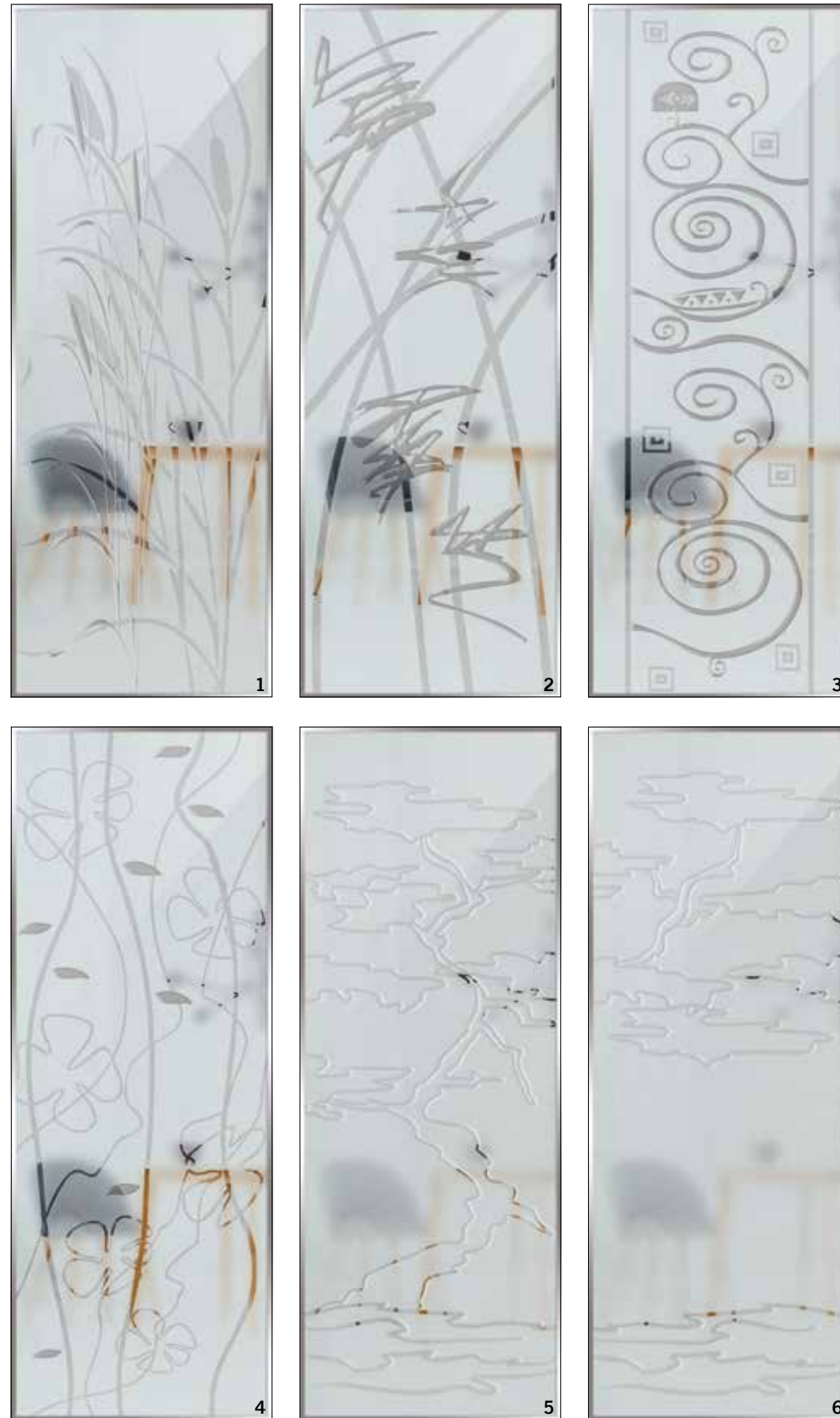

**VETRI STAMPA DIGITALE**  
DIGITAL PRINT  
GLASS

1. Anthea  
*Anthea*
2. Abstract  
*Abstract*
3. Capitali  
*Capitali*
4. Gran dama (6 colori)  
*Gran dama (6 colours)*
5. Hippy (6 colori)  
*Hippy (6 colours)*
6. Mondrian  
*Mondrian*



**VETRI SABBATI**  
**FLESSYA**  
*FLESSYA SANDED*  
 GLASS

- 1. NS00  
NS00
- 2. NS05  
NS05
- 3. NS08  
NS08
- 4. NR00  
NR00
- 5. NR13  
NR13
- 6. NR20  
NR20
- 7. NR30  
NR30
- 8. NR31  
NR31
- 9. N15  
N15
- 10. N15A  
N15A
- 11. NF00  
NF00
- 12. P31  
P31

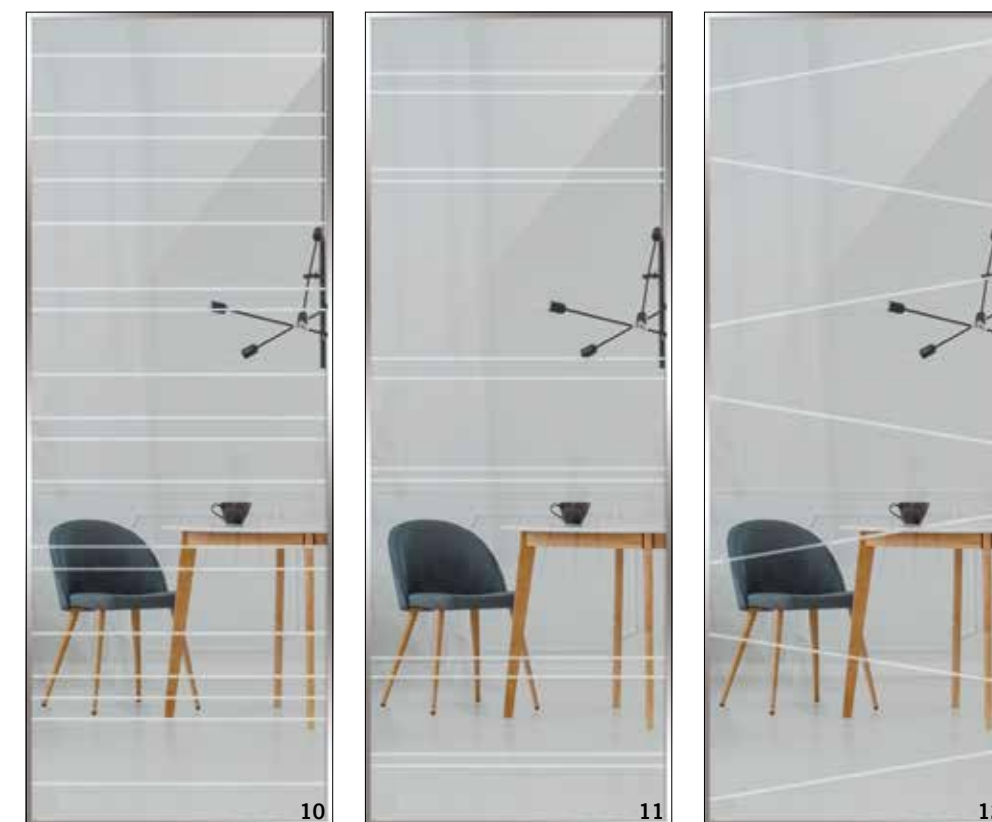

# DISEGNI TECNICI / Battenti

## TECHNICAL DRAWS / Hinged

### TRATTO

Porta battente per muro con controtelaio in legno  
Hinged door for wall with wooden counter-frame

- A. Anta singola  
Single leaf
- B. Anta doppia  
Double leaf

- H Luce netta passaggio  
Net passage clearance
- H1 Esterno telaio  
External frame
- H2 Interno controtelaio  
Internal counter-frame
- H3 Esterno cornice  
External moulding
- L Luce netta passaggio  
Net passage clearance
- L1 Esterno telaio  
External frame
- L2 Interno controtelaio  
Internal counter-frame
- L3 Esterno cornice  
External moulding

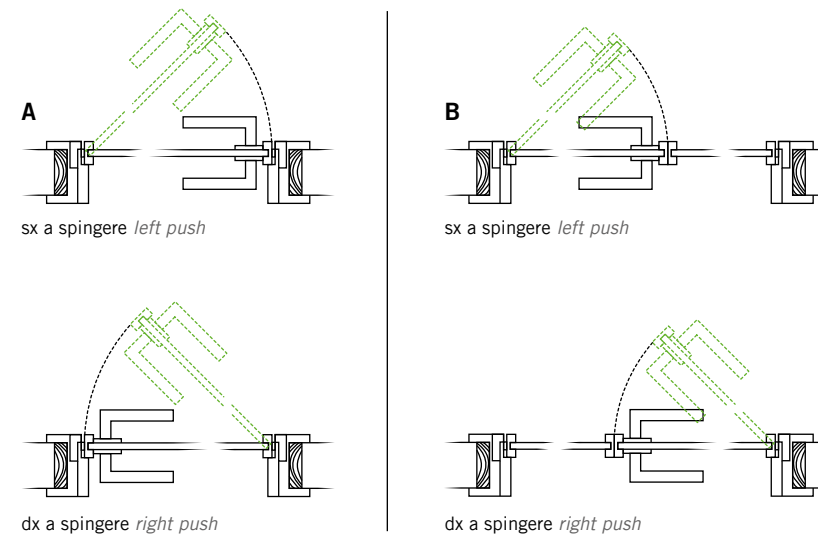
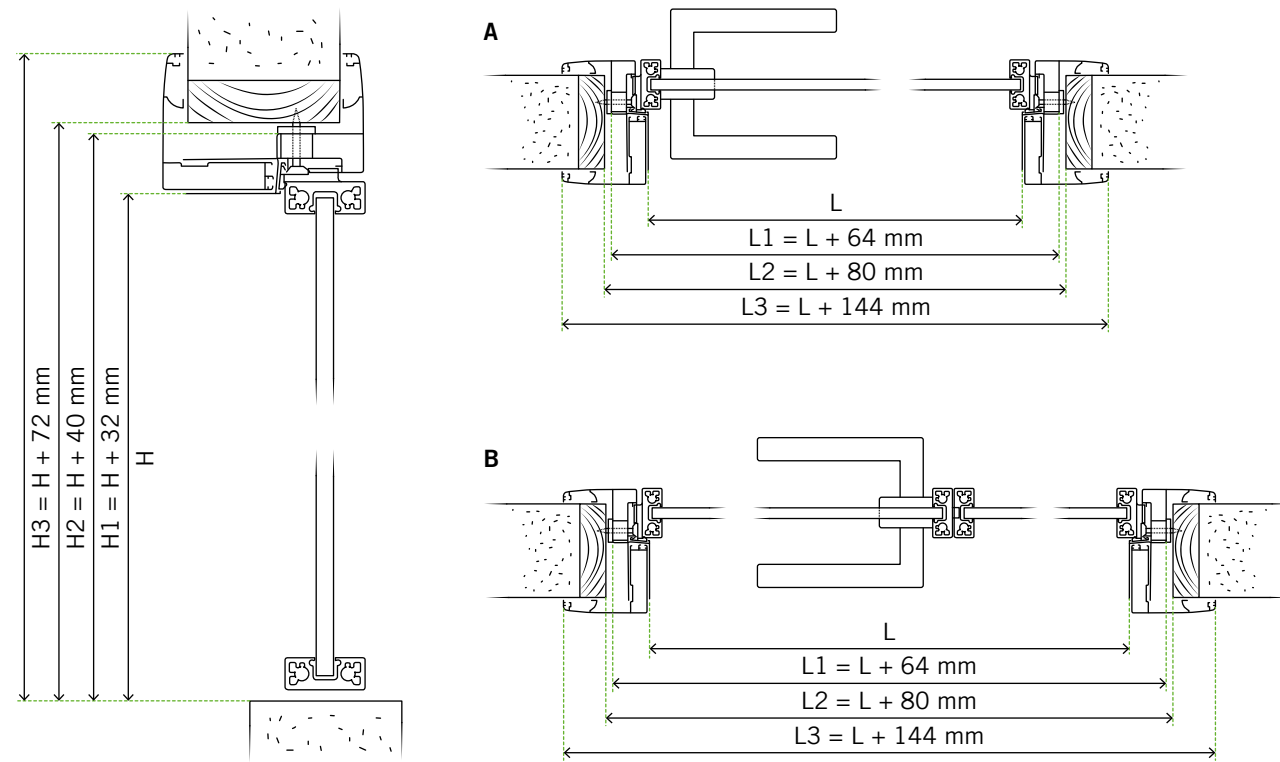

### MINIMALE

Porta battente per muro finito  
Hinged door for finished wall

- A. Anta singola  
Single leaf
- B. Anta doppia  
Double leaf

- H Luce netta passaggio  
Net passage clearance
- H1 Esterno telaio  
External frame
- H2 Interno controtelaio  
Internal counter-frame
- L Luce netta passaggio  
Net passage clearance
- L1 Esterno telaio  
External frame
- L2 Interno controtelaio  
Internal counter-frame

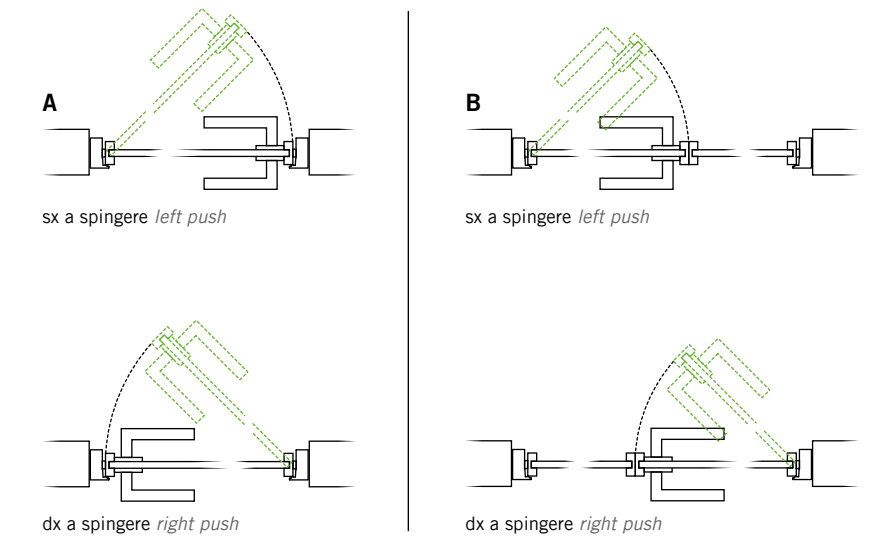
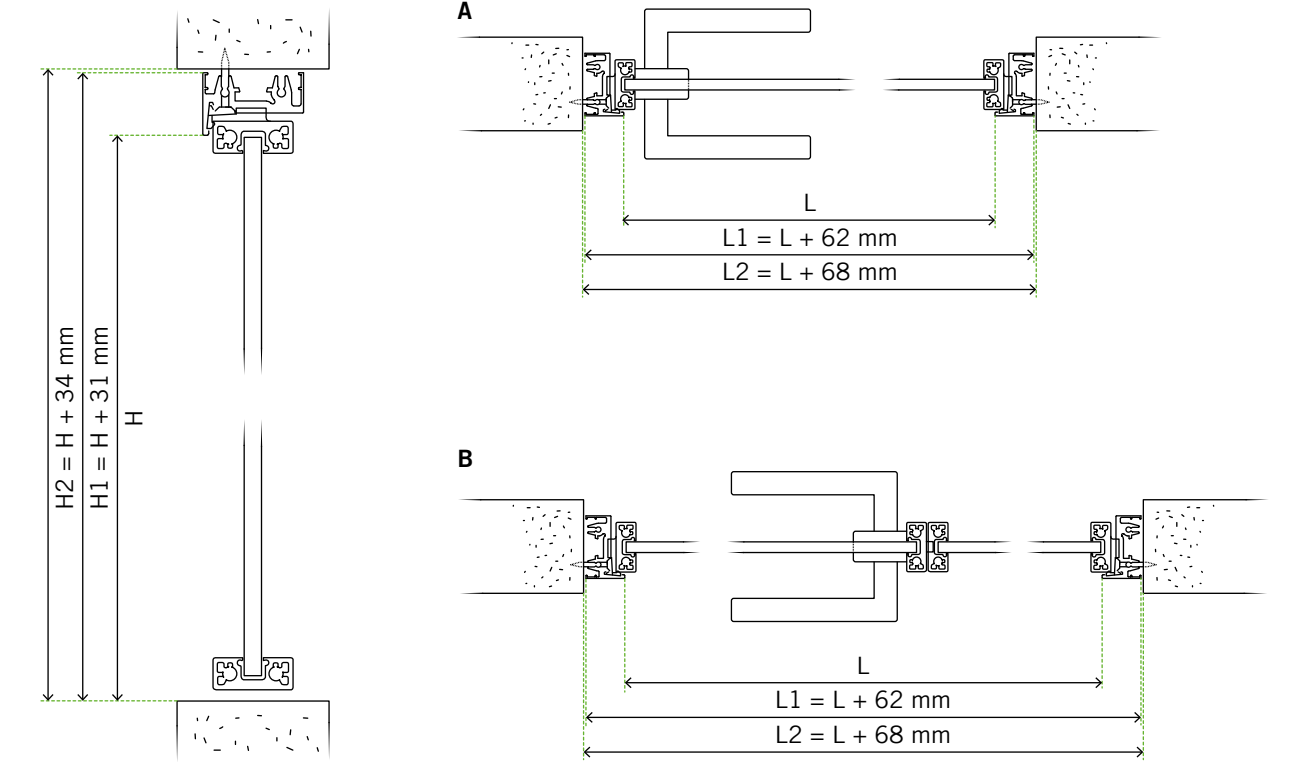



# DISEGNI TECNICI / Scorrevoli a scomparsa

## TECHNICAL DRAWS / Pocket sliding

### TRATTO

Porta scorrevole a scomparsa  
Pocket sliding door

- A. Anta singola  
Single leaf
- B. Anta doppia  
Double leaf

- H Luce netta passaggio  
Net passage clearance
- H1 Esterno telaio  
External frame
- H2 Esterno cornice  
External moulding
- L Luce netta passaggio  
Net passage clearance
- L1 Esterno telaio  
External frame
- L2 Esterno cornice  
External moulding

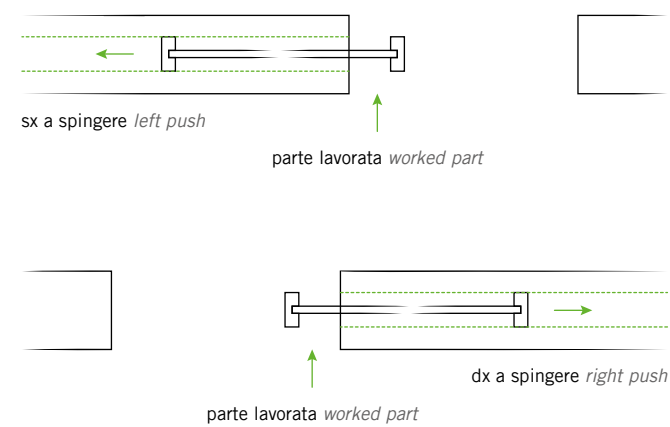
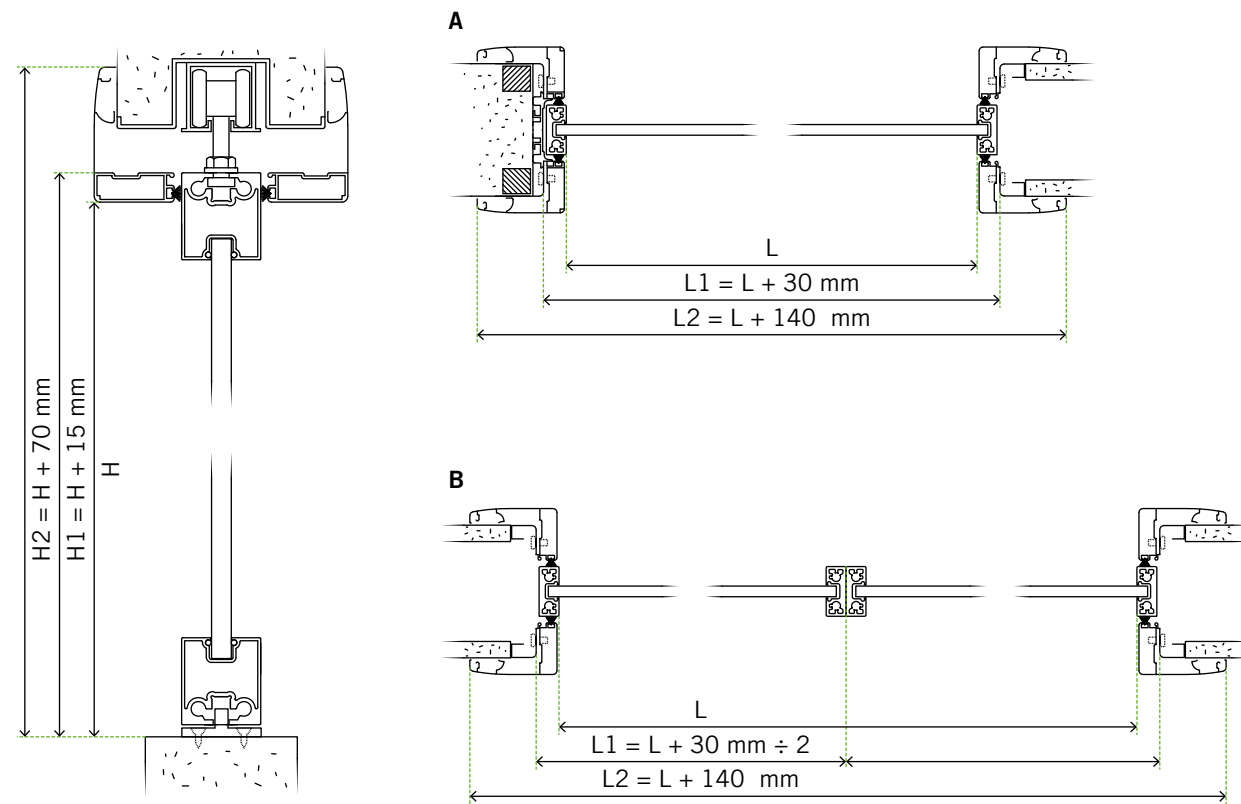

### ESSENTIAL

Porta scorrevole a scomparsa  
senza telaio  
Pocket sliding door  
without frame

- A. Anta singola  
Single leaf
- B. Anta doppia  
Double leaf

- H Luce netta passaggio  
Net passage clearance
- H1 Anta finita  
Finished leaf
- L Luce netta passaggio  
Net passage clearance
- L1 Anta finita  
Finished leaf

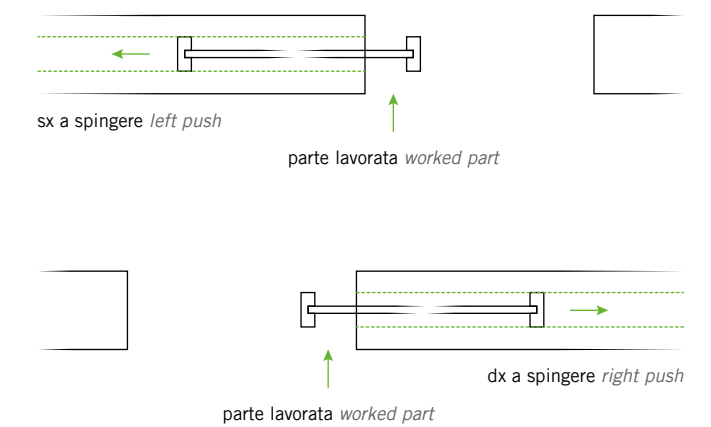
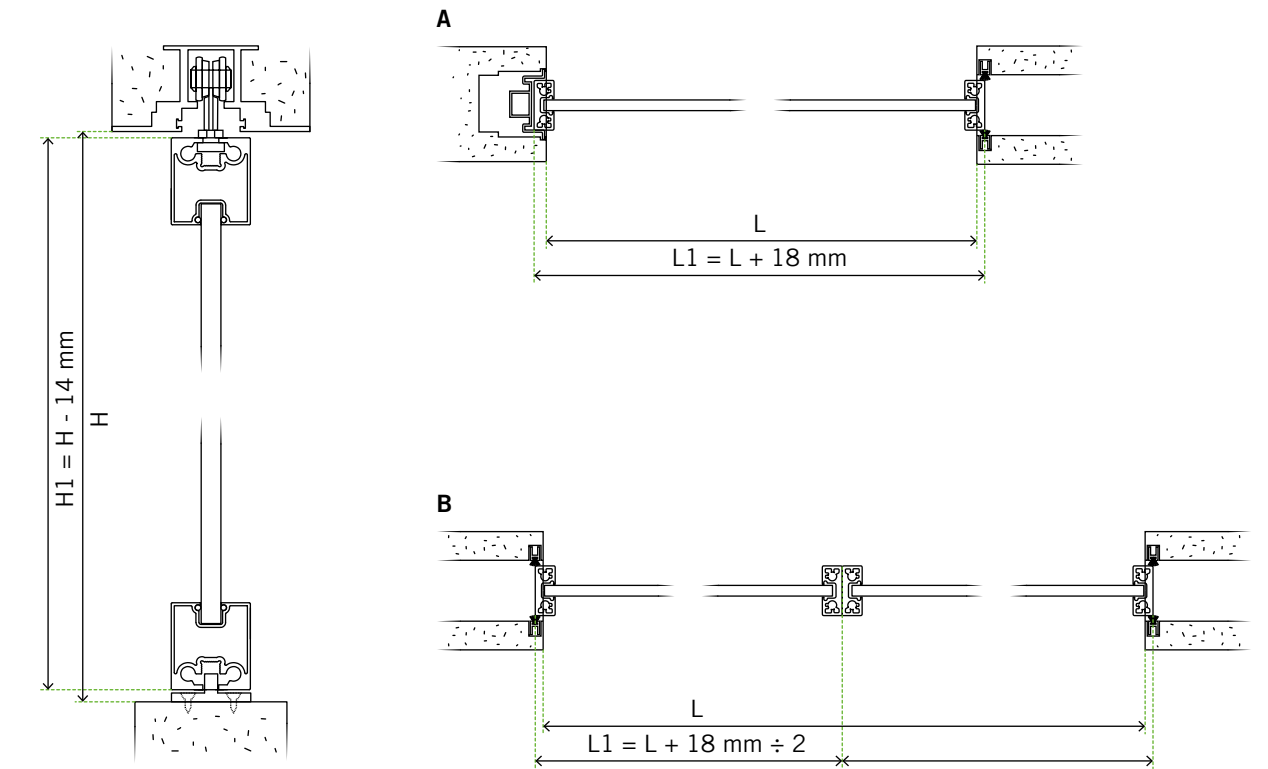

# DISEGNI TECNICI / Scorrevoli esterni

## TECNICAL DRAWS / External sliding

Porta scorrevole esterno  
External sliding door

1. **Binario incassato**  
Recessed track
2. **Attacco a soffitto**  
Ceiling mount
3. **Attacco a parete**  
Wall mount

- A. **Anta singola**  
Single leaf
- B. **Anta doppia**  
Double leaf

- H Luce netta passaggio  
Net passage clearance
- H1 Anta finita  
Finished leaf
- L Luce netta passaggio  
Net passage clearance
- L1 Anta finita  
Finished leaf

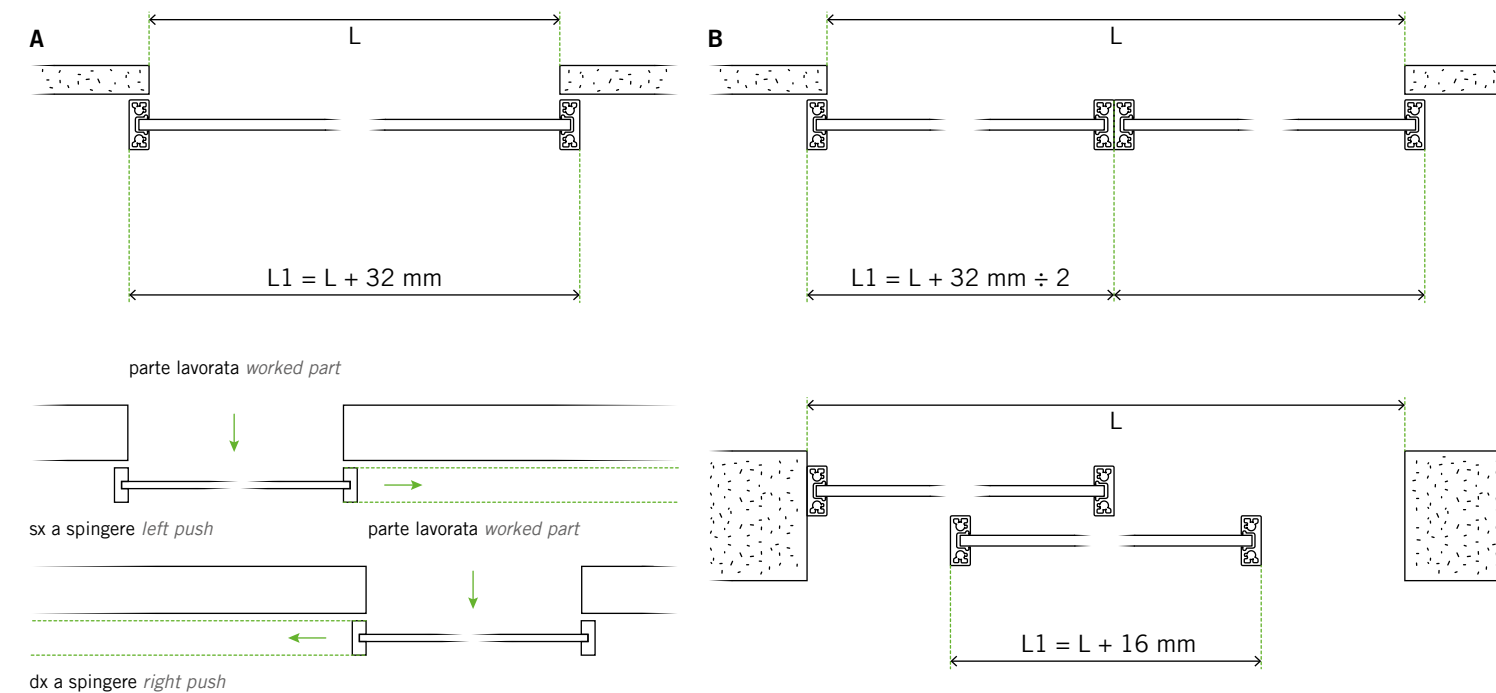
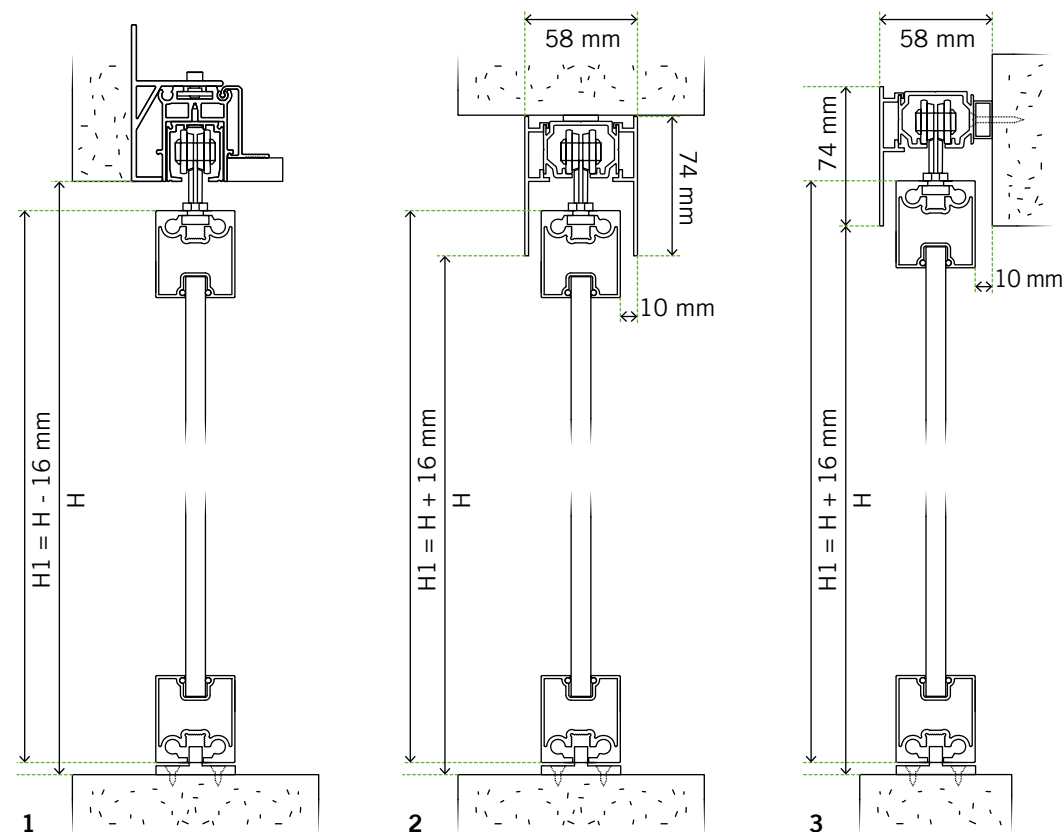

## MANIGLIE / Battenti

HANDLES / Hinged door

1. Mira foro patent  
*Mira patent hole*
2. Mira con nottolino  
*Mira with knob*
3. Mira con cilindro yale  
*Mira with yale cylinder*
4. Quadra foro patent  
*Quadra patent hole*
5. Quadra con nottolino  
*Quadra with knob*
6. Quadra con cilindro yale  
*Quadra with yale cylinder*

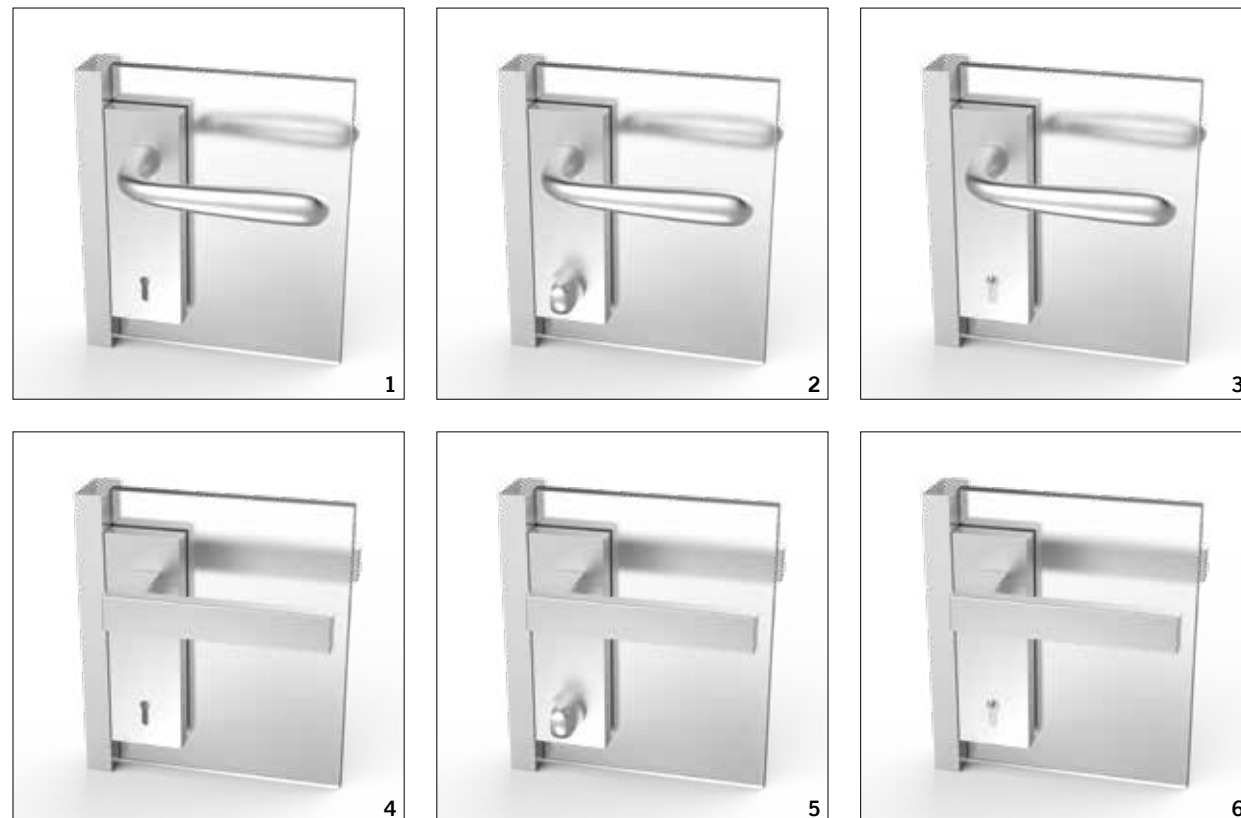

## MANIGLIE / Scorrevoli

HANDLES / Sliding door

1. Rettangolare  
acciaio inox 64x150 mm  
*Regular stainless steel  
64x150 mm*
2. Quadrata  
acciaio inox 64x64 mm  
*Square stainless steel  
64x64 mm*
3. A 'C' argento  
172 mm o 332 mm  
*'C' silver 172 mm  
or 332 mm*
4. A 'L' argento  
o in tutte le finiture  
140 mm, 500 mm  
o 1000 mm  
*'L' silver or in all finishes  
140 mm, 500 mm  
or 1000 mm*
5. Kit di chiusura  
per scorrevole  
lato interno argento  
*Internal side sliding  
silver closure kit*
6. Kit di chiusura  
per scorrevole  
lato esterno argento  
*External side sliding  
silver closure kit*

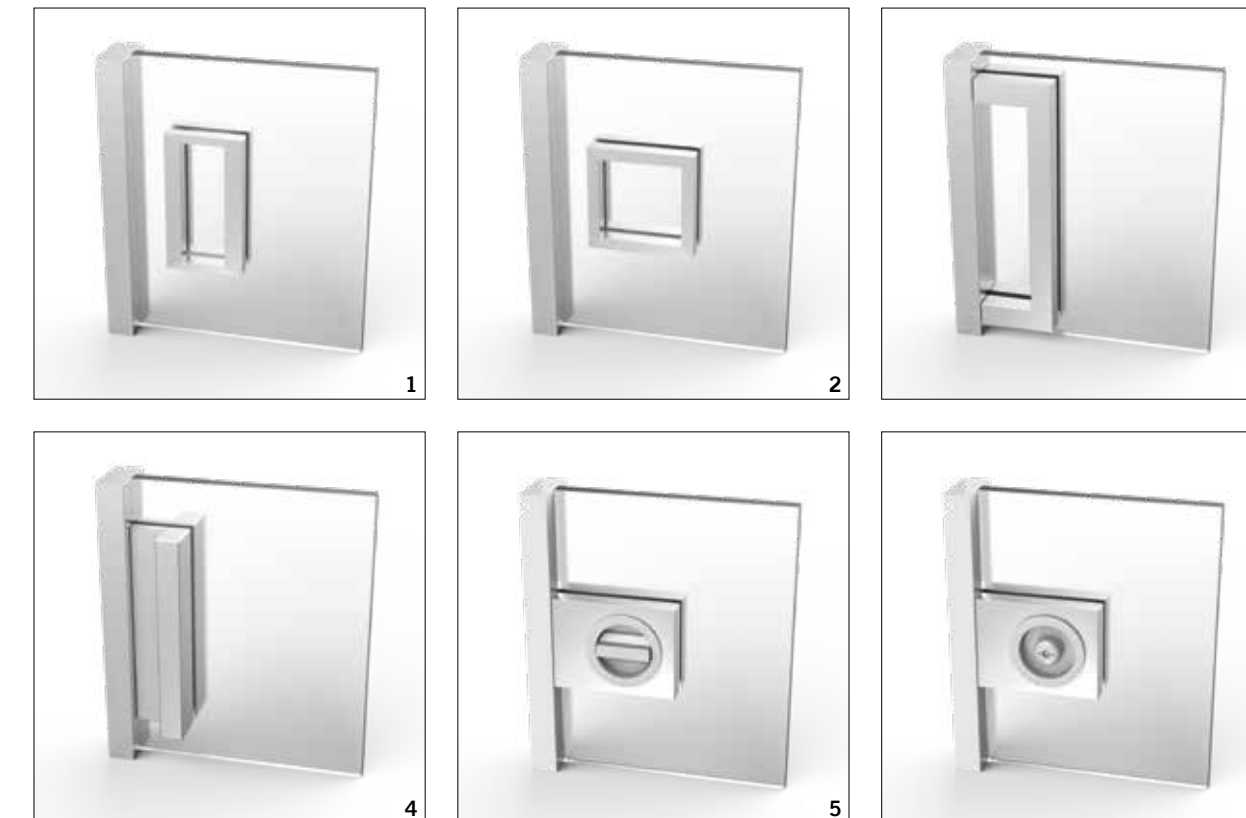

# D U O

Due, come i vetri che si uniscono per raddoppiare la materialità. L'armonia nata dal contrasto tra forza e leggerezza, che riesce a rendere semplice anche ciò che si presenta come eccezionale. Con **S-nziale Duo** la superficie diventa più importante amplificando la sua eleganza e la sua semplicità.

*Two, like the glass that combine to double the matter. The harmony that emerges from the contrast between strength and levity, that can even make something that seems exceptional, simple. With **S-nziale Duo**, the surface becomes more important, intensifying its elegance and simplicity.*



**SD00**

**Battente TRATTO**  
Alluminio: bianco  
Vetro: acidato extra chiaro

*TRATTO hinged*  
Aluminium: white  
Glass: extra clear frosted

**SD00**

**Scorrevole ESSENTIAL**  
Alluminio: nero  
Vetro: trasparente grigio

*ESSENTIAL sliding*  
Aluminium: black  
Glass: transparent grey





#### **SD00**

**Libro asimmetrica 3 ante  
con anta fissa laterale**  
Alluminio: argento  
Vetro: trasparente e  
laccato ral 1019

*Asymmetrical folding 3 leaves  
with fixed side leaf*  
Aluminium: silver  
Glass: transparent and  
lacquered ral 1019



## SD00

**Scorrevole parallelo interno**  
Alluminio: argento  
Vetro: trasparente  
grigio semiriflettente

*Parallel internal sliding*  
Aluminium: silver  
Glass: semi-reflective  
transparent grey



SD00

**Battente TRATTO**  
Alluminio: argento  
Vetro: laccato bianco

*TRATTO hinged*  
Aluminium: silver  
Glass: white lacquered





**SD00**

**Battente TRATTO**  
Alluminio: argento  
Vetro: acidato

*TRATTO hinged*  
Aluminium: silver  
Glass: frosted

**SD00**

**Scorrevole a scomparsa**  
Alluminio: argento  
Vetro: acidato

*Pocket sliding*  
Aluminium: silver  
Glass: frosted

**SD00**

**Scorrevole esterno  
attacco a soffitto**  
Alluminio: bianco  
Vetro: specchio

*Ceiling mounted  
external sliding*  
Aluminium: white  
Glass: mirror





**SD00**

**Battente MINIMAL**  
Alluminio: argento  
Vetro: acidato

*MINIMAL hinged*  
Aluminium: silver  
Glass: frosted



**SD00** Scorrevole esterno attacco a parete / Alluminio: bianco / Vetro: trasparente  
Wall mounted external sliding / Aluminium: white / Glass: transparent

**SD00**

**Scorrevole ESSENTIAL**  
Alluminio: nero  
Vetro: trasparente bronzo

*ESSENTIAL sliding*  
Aluminium: black  
Glass: transparent bronze



**SD00**

**Scorrevole parallelo interno**  
Alluminio: nero  
Vetro: trasparente bronzo

*Parallel internal sliding*  
Aluminium: black  
Glass: transparent bronze

# D U O

## DETTAGLI TECNICI TECHNICAL DETAILS

La linea **S-nziale Duo** è realizzata con una coppia di vetri temperati, fissati su un telaio in alluminio interno all'anta. I vetri monolitici hanno uno spessore di 5 mm e si possono realizzare nella versione trasparente, acidata oppure laccata in vari colori. Il bordo in alluminio a vista è di soli 3 mm ed i vetri acidati vengono serigrafati perimetralmente per nascondere la sottostruttura in alluminio.

*The **S-nziale Duo** line is made with a pair of tempered glasses, secured on an aluminium frame in the leaf. Single slab glass is 5 mm thick and can be made in the transparent or frosted versions or lacquered in various colours. The visible aluminium edge is only 3 mm and frosted glass is silk-screened around the edge to hide the aluminium sub-structure.*

# FINITURE

## FINISHES

### ALLUMINIO ALUMINIUM

1. Argento  
*Silver*
2. Bianco  
*White*
3. Nero  
*Black*
4. Testa di moro  
*Dark brown*

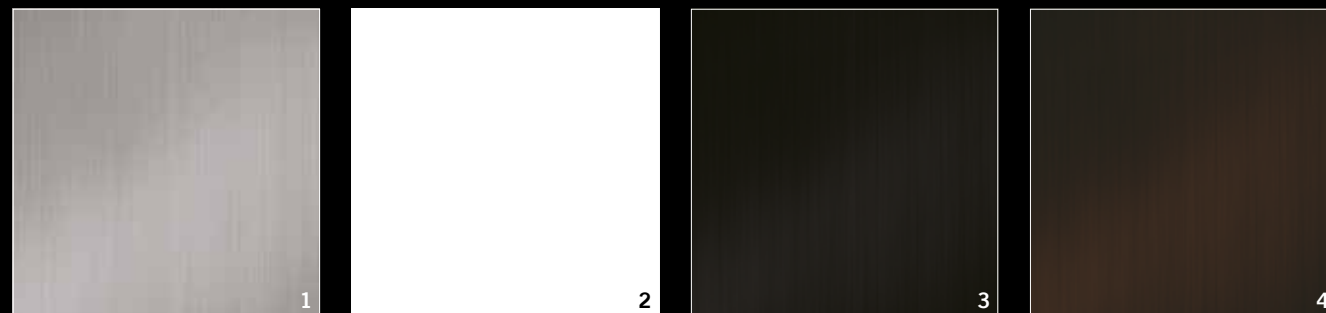

### VETRI TRASPARENTI TRANSPARENT GLASS

1. Trasparente  
*Transparent*
2. Trasparente extra chiaro  
*Extra clear transparent*
3. Trasparente bronzo  
*Transparent bronze*
4. Trasparente grigio  
*Transparent grey*
5. Trasparente arancio  
*Transparent orange*
6. Trasparente porpora  
*Transparent purple*
7. Trasparente rosso  
*Transparent red*
8. Trasparente blu  
*Transparent blue*
9. Semiriflettente grigio  
*Semi-reflective grey*

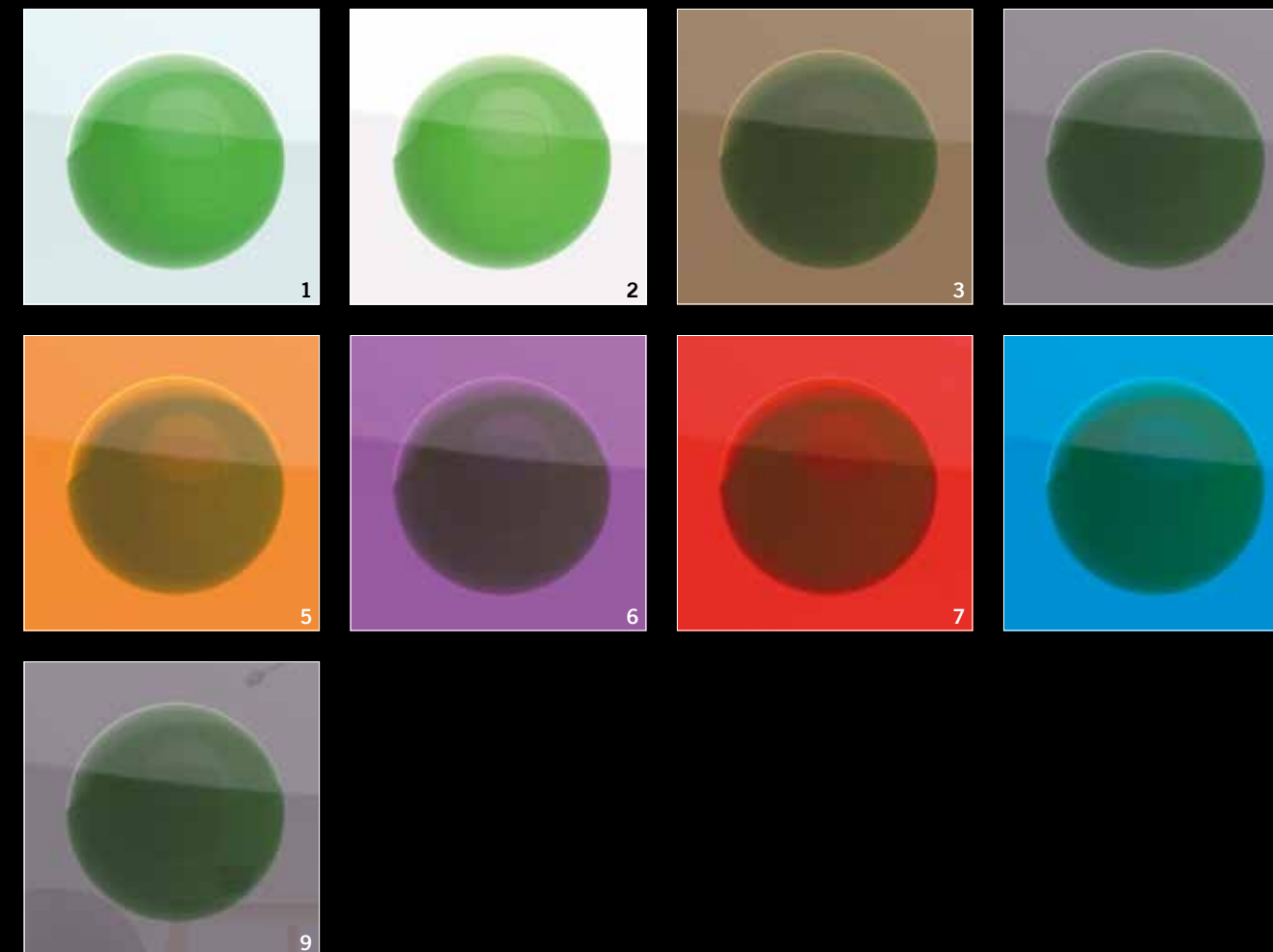



**VETRI ACIDATI**  
*FROSTED GLASS*

1. Acidato  
*Frosted*
2. Acidato extra chiaro  
*Extra clear frosted*
3. Acidato bronzo  
*Frosted bronze*
4. Acidato grigio  
*Frosted grey*
5. Acidato arancio  
*Frosted orange*
6. Acidato porpora  
*Frosted purple*
7. Acidato rosso  
*Frosted red*
8. Acidato blu  
*Frosted blue*

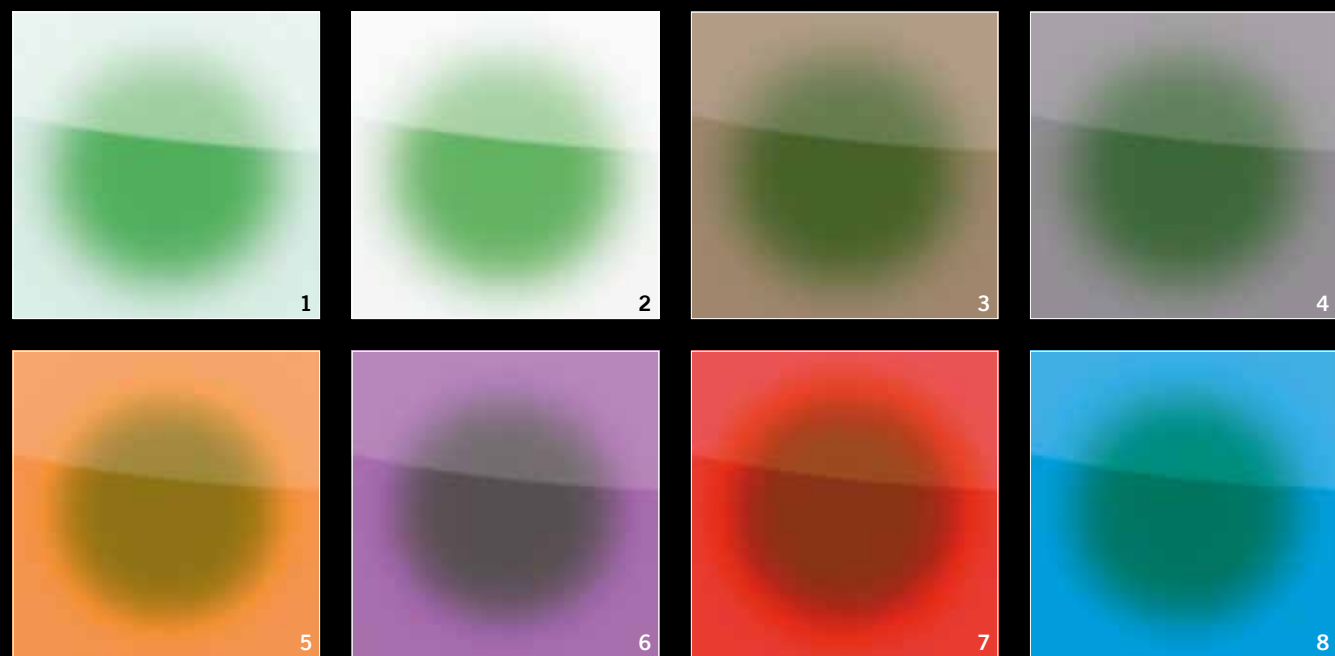

**VETRI LACCATI**  
*LACQUERED GLASS*

1. Laccato bianco  
*White lacquered*
2. Laccato nero  
*Black lacquered*
3. Laccato rosso  
*Red lacquered*
4. Specchio  
*Mirror*

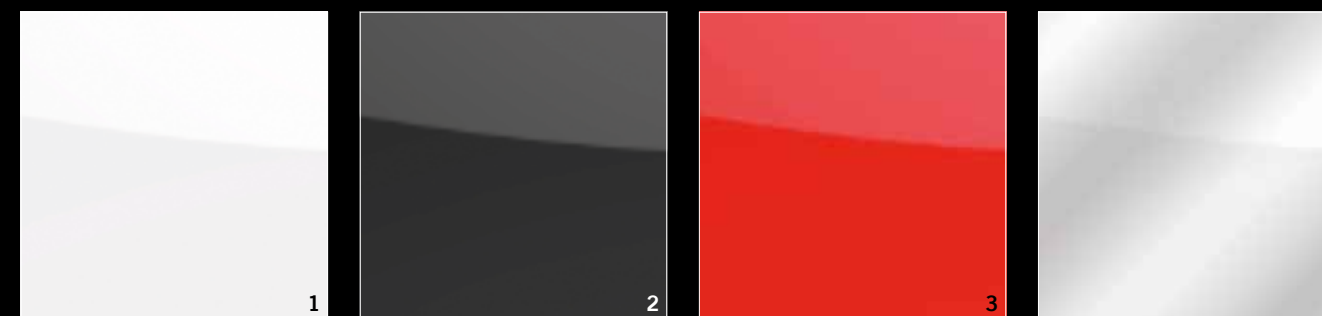

# DISEGNI TECNICI / Battenti

## TECHNICAL DRAWS / Hinged

### TRATTO

Porta battente per muro con controtelaio in legno  
*Hinged door for wall with wooden counter-frame*

- A. Anta singola  
*Single leaf*
- B. Anta doppia  
*Double leaf*

- H Luce netta passaggio  
*Net passage clearance*
- H1 Esterno telaio  
*External frame*
- H2 Interno controtelaio  
*Internal counter-frame*
- H3 Esterno cornice  
*External moulding*
- L Luce netta passaggio  
*Net passage clearance*
- L1 Esterno telaio  
*External frame*
- L2 Interno controtelaio  
*Internal counter-frame*
- L3 Esterno cornice  
*External moulding*

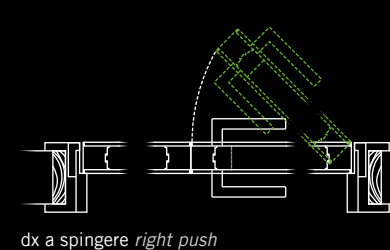
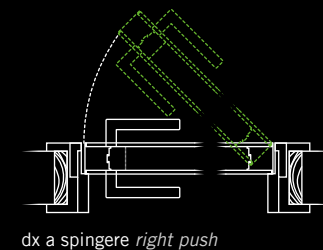
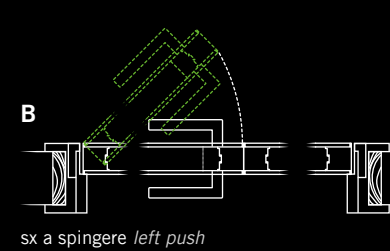
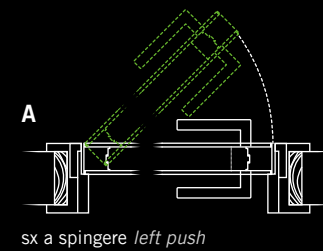
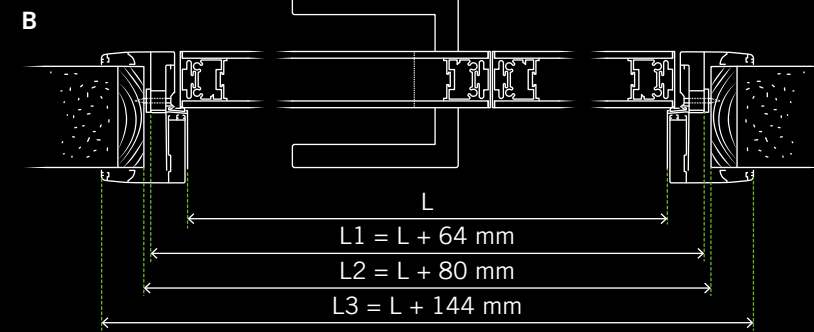
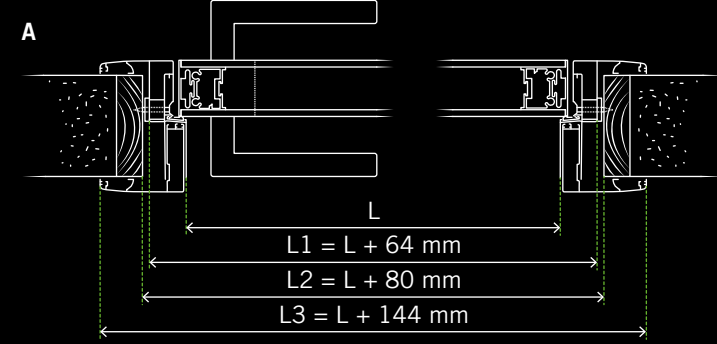
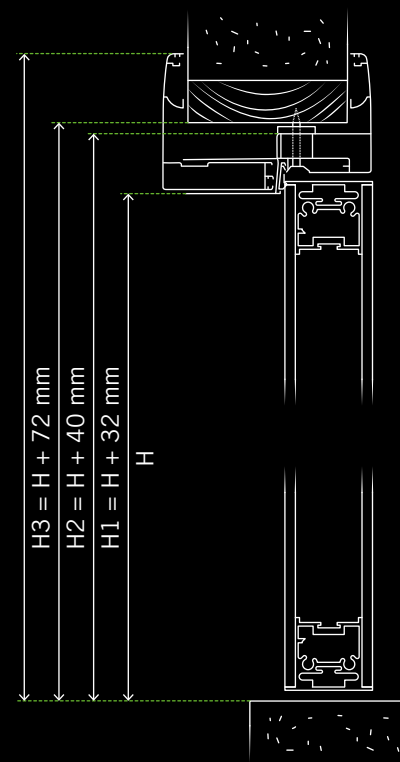

### MINIMALE

Porta battente per muro finito  
*Hinged door for finished wall*

- A. Anta singola  
*Single leaf*
- B. Anta doppia  
*Double leaf*

- H Luce netta passaggio  
*Net passage clearance*
- H1 Esterno telaio  
*External frame*
- H2 Interno controtelaio  
*Internal counter-frame*
- L Luce netta passaggio  
*Net passage clearance*
- L1 Esterno telaio  
*External frame*
- L2 Interno controtelaio  
*Internal counter-frame*

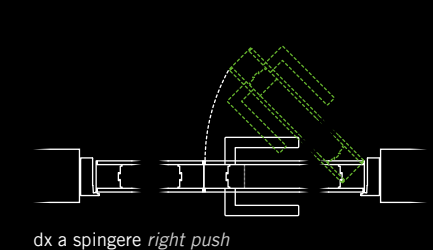
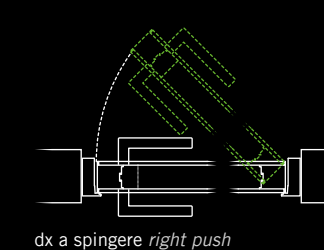
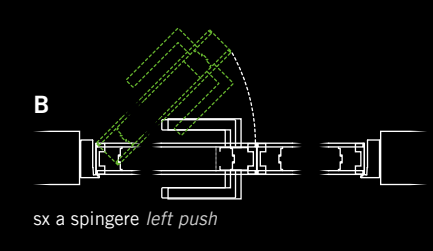
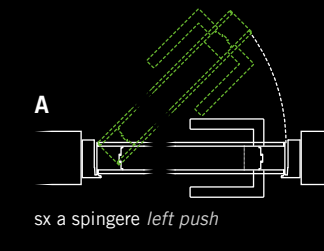
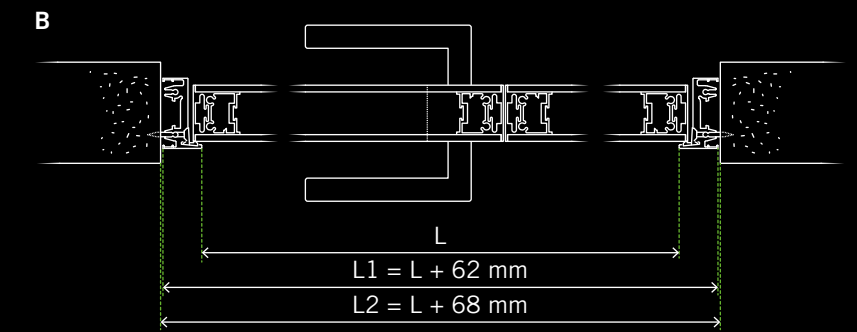
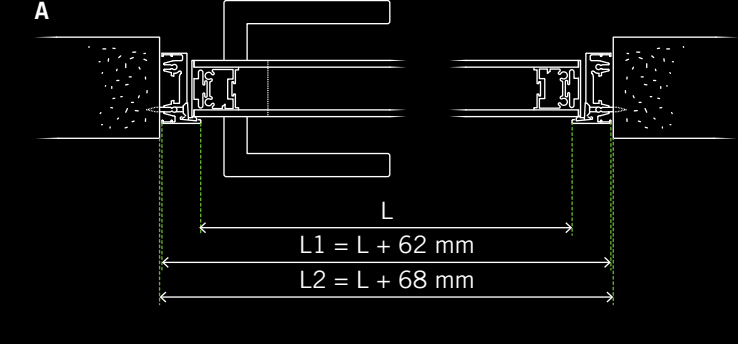
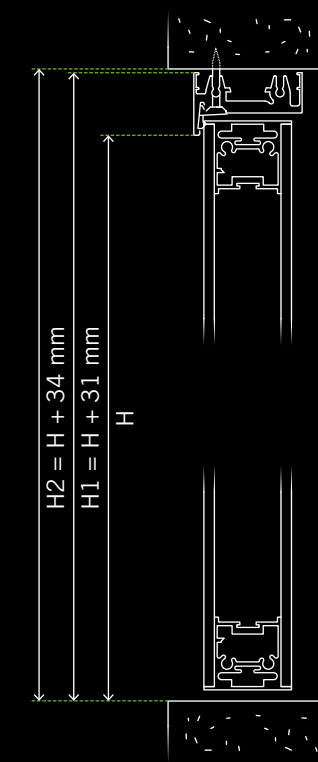

# DISEGNI TECNICI / Scorrevoli a scomparsa

## TECHNICAL DRAWS / Pocket sliding

### TRATTO

Porta scorrevole a scomparsa  
Pocket sliding door

- A. Anta singola  
Single leaf
- B. Anta doppia  
Double leaf

- H Luce netta passaggio  
Net passage clearance
- H1 Esterno telaio  
External frame
- H2 Esterno cornice  
External moulding
- L Luce netta passaggio  
Net passage clearance
- L1 Esterno telaio  
External frame
- L2 Esterno cornice  
External moulding

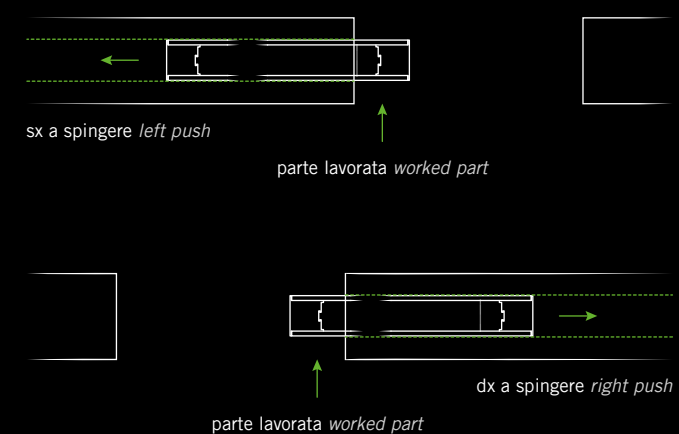
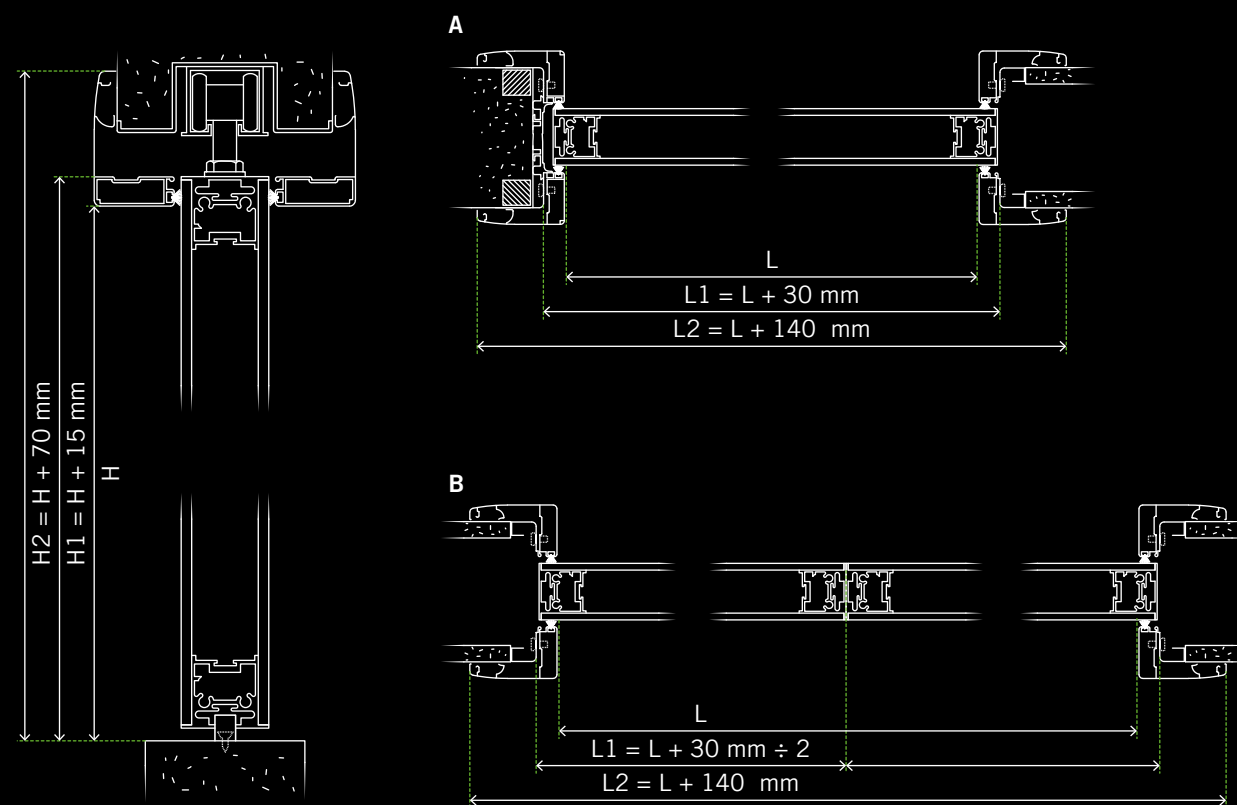

### ESSENTIAL

Porta scorrevole a scomparsa  
senza telaio  
Pocket sliding door  
without frame

- A. Anta singola  
Single leaf
- B. Anta doppia  
Double leaf

- H Luce netta passaggio  
Net passage clearance
- H1 Anta finita  
Finished leaf
- L Luce netta passaggio  
Net passage clearance
- L1 Anta finita  
Finished leaf

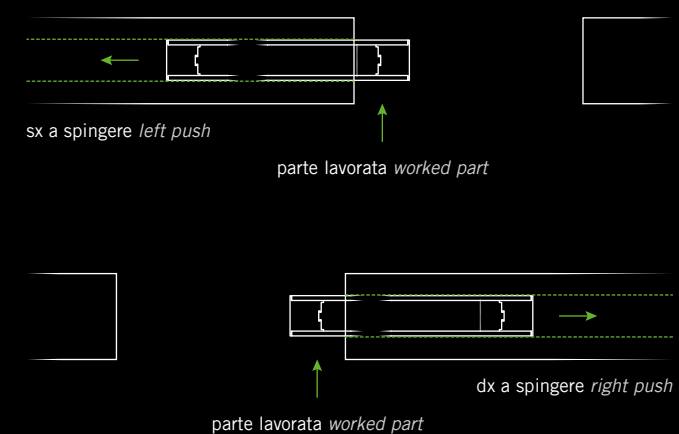
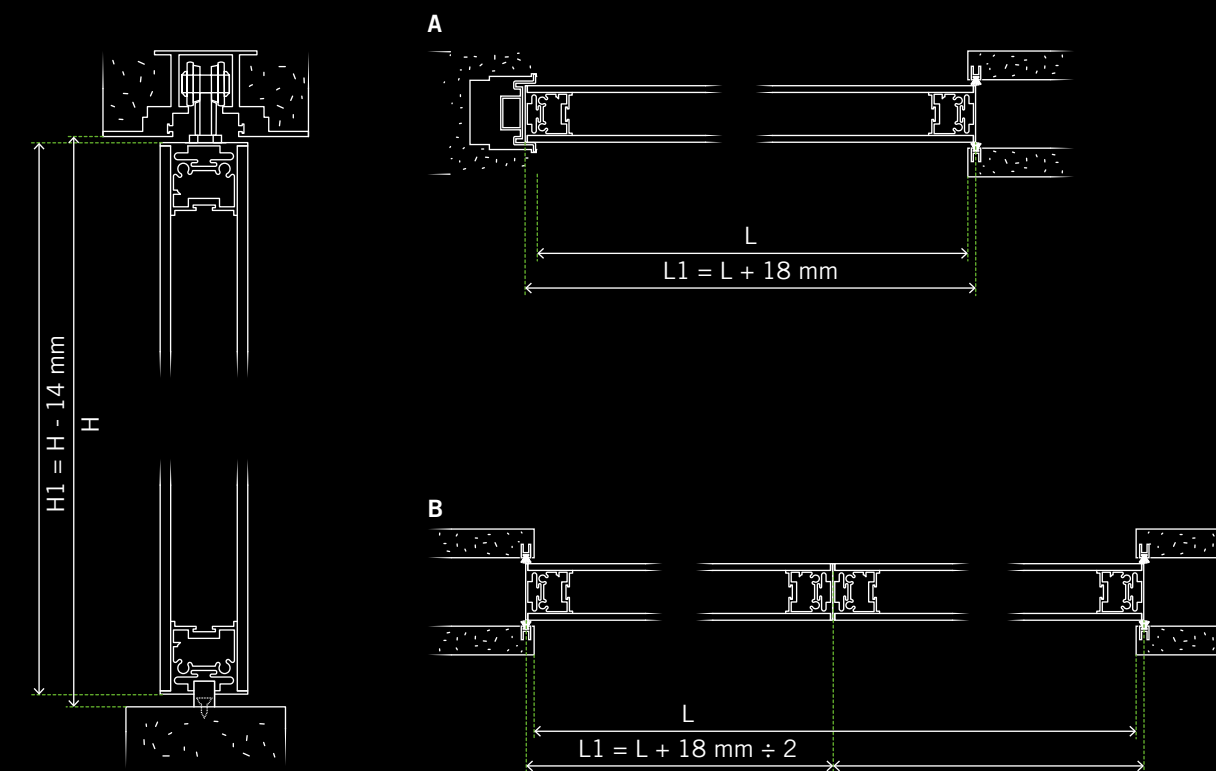



**MANIGLIE / Battenti**  
*HANDLES / Hinged door*

---

- 1. Quadra foro patent  
*Quadra patent hole*
- 2. Quadra con nottolino  
*Quadra with knob*



**MANIGLIE / Scorrevoli**  
*HANDLES / Sliding door*

---

- 1. Maniglia ovale  
*Oval handle*
- 2. Kit di chiusura  
*Closure kit*





**Flessya Srl**

via dell'Artigianato 13  
60030 Monte Roberto AN  
p.iva 02287520429  
tel 0731.70.74.11  
fax 0731.70.74.70  
[www.flessya.com](http://www.flessya.com)  
info@flessya.it  
commerciale@flessya.it  
amministrazione@flessya.it

Amplifica l'esperienza con il nostro catalogo attraverso il tuo tablet, scarica la nostra **App disponibile per Android e iOS** e scopri tutte le informazioni sui nostri prodotti.

All'interno potrai trovare video, esperienze con i prodotti, la possibilità di configurare la tua porta e molto altro.

*Expand experience with our catalogue with your tablet, download our **App available for Android and iOS** and learn everything you need to know about our products.*

*You'll find videos, experiences with products, the chance to design your door and much more.*



I colori riportati sono puramente indicativi.

*The brought colors are purely indicative.*

COMBOS

